

Ice storage and transport system

with gravity dispense cart loading



E-ITS100NS-31



E-ITS500NS-31



E-ITS1350SG-60



E-ITS700SG-31



ITS2250SG-60



ITS3250SG-90



Features

Designed with speed, safety and sanitation in mind

- elevated ice storage bin uses gravity to dispense ice through a chute 15 times faster than scooping
- one pull of the gate bar fills the SmartCART™ 240 ice cart with 109 kg (240 lb) of ice without any hand contact
- dispensing directly into cart eliminates scooping by hand to help prevent cross-contamination
- cart reduces the risk of back injuries by eliminating carrying containers of ice
- optional Totes™ ice carriers may be ordered – SmartCART 240 will hold 6 Totes for use in applications where the ice needs to be lifted out of the SmartCART 240
- industry exclusive SmartGATE® ice shield controls the flow of ice to reduce spills and limits contact with ice (E-ITS700-31 and E-ITS1350SG-60 only)

Fresher ice

- first ice in is first ice out

Ice compatibility

- Compatible with cube ice, flake ice and Chewblet® ice

Durable, user friendly construction

- 78.7 cm (31.00") width allows use in limited space (E-ITS1350SG-60 is 152.4 cm (60.00") wide)
- full stainless bin exterior and base
- corrosion-resistant poly bin liner and custom-cut stainless top
- heavy duty "stay-open" PowerHinge™ door hinge – easy one hand open and close without door catches (E-ITS700SG-31 and E-ITS1350SG-60)

SmartCART 240 insulated all-poly carts

- cart drains to bin system when parked in bay

Includes:

- one, two or three SmartCART 240 ice transport cart(s) depending on model
- paddle with hanging bracket (except E-ITS100NS-31)

Warranty

- visit follettice.com for complete warranty details
- 3rd party ice machines must be installed and operated in accordance with the manufacturer's instructions

Accessories

- Set of 6 Totes ice carriers (Totes not standard) (item# ABICETOTP)
- SmartCART 240 ice cart (item# 00122770)
- Plastic shovel (item# ABICSHOVEL)
- Ice paddle (item# ABICEPADDL)
- Partition (2 and 3 bay only)
- Additional carts and accessories (refer to form# 3435)

Mokry Dwór 26C 83-021 Wiślina, Poland
Phone: +48 (58) 785-6140 | Fax: +48 (58) 785-6159
folletteurope.com

801 Church Lane | Easton, PA 18040, USA
1.610.252.7301 | Fax: +1.610.250.0696 | follettice.com

FOLLETT®

Specification

Maximum bin capacity ¹	see model table below
W1 Bin width	see model table below
D1 Bin depth ²	101.6 cm (40.00")
D2 Bin depth with door fully extended	add 20.32 cm (8.00")
H1 Bin height (adjustable) ³	see model table below
H2 Bin base height (adjustable)	98.4 cm (38.75")
Required door access ⁴	see model table below
W2 Cart width	62.2 cm (24.50")
D3 Cart depth	105.4 cm (41.50")
H3 Cart height at front edge	88.9 cm (35.00")
H4 Cart height at rear edge	71.1 cm (28.00")
W3 Tote width	39.7 cm (15.62")
D4 Tote depth	18.08 cm (7.12")
H5 Tote height	38.1 cm (15.00")
C1 Drain ⁵	1.25" ID PVC female slip fit (reversible to opposite side)
Dispense rate	up to 2.3 kg (5 lb) per second
Ice compatibility	cube ice, flake ice and Chewblet ice
Shipping weight	see model table below

NOTE: For indoor use only.

SHORT FORM SPECIFICATION: Ice transport system to be Follett model _____ equipped with SmartCART 240 ice transport cart(s). Elevated bin to hold approximately _____ kg (lb) of ice. Exterior of bin and base to be full stainless steel. All bins (except E-ITS500NS-31, E-ITS600NS-31 and E-ITS100NS-31) to have polyethylene ice access door assembly, polyethylene lift door with PowerHinge door hinge, and SmartGATE ice shield. Stainless steel bin top to be custom-cut for ice machine(s) to be used. Bin liner walls to be of non-corroding polyethylene and insulated with non-CFC foam polyurethane. Bin hopper to be of polyethylene with extra large opening(s) to facilitate ice flow. Base to have built-in drains for bins and carts, and insulated drain troughs, shutter door, and drain to minimize condensation. Cart(s) to be of insulated one-piece molded polyethylene, with plastic lid, four heavy-duty casters (two swivel with one step-on lock and two non-swivel). Carts and optional Totes ice carriers to store below bin when not in use and to drain when positioned in bay. All models to have adjustable flanged feet and paddle. NSF-listed.

Dimensional drawing

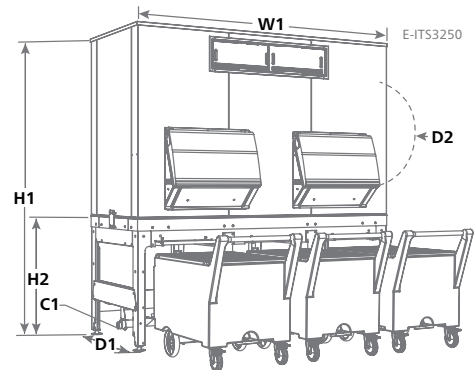
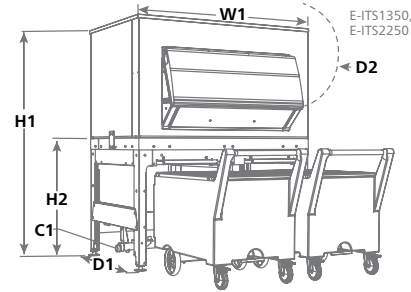
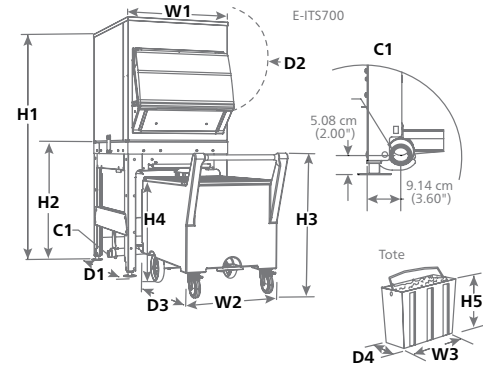

POWERHINGE, SMARTCART and TOTES are trademarks of Follett Products, LLC. CHEWBLET, FOLLETT and SMARTGATE are registered trademarks of Follett Products, LLC, registered in the US. Follett reserves the right to change specifications at any time without obligation. Certifications may vary depending on country of origin.

Model	Number of carts	Maximum bin capacity kg (lb) ¹	Maximum capacity with carts kg (lb) ^{1,6}	Width - W1 cm (in)	Height - H1 cm (in) ^{3,4}	Required access cm (in) ⁴	Approximate ship weight kg (lb)
E-ITS100NS-31	1	46 (100)	155 (340)	78.7 (31.00)	119.4 (47.00)	81.3 (32.00)	110 (243)
E-ITS500NS-31 ⁷	1	174 (382)	283 (622)	78.7 (31.00)	152.4 (60.00)	81.3 (32.00)	169 (371)
E-ITS600NS-31 ⁷	1	273 (600)	382 (840)	78.7 (31.00)	170.2 (67.00)	81.3 (32.00)	176 (388)
E-ITS700SG-31 ⁸	1	296 (652)	405 (892)	78.7 (31.00)	190.5 (75.00)	81.3 (32.00)	181 (398)
E-ITS1350SG-31 ⁸	2	602 (1327)	712 (1567)	152.4 (60.00)	190.5 (75.00)	104.1 (41.00)	380 (838)
ITS2250SG-60	2	968 (2133)	1077 (2373)	152.4 (60.00)	246.4 (97.00)	104.1 (41.00)	374 (822)
ITS3250SG-90	3	1477 (3255)	1586 (3495)	228.6 (90.00)	246.4 (97.00)	104.1 (41.00)	521 (1145)

Notes:

- Computed on cubic volume of bin. Does not reflect cart capacity or voids that can occur due to pyramiding.
- Add 20.32 cm (8.00") to depth (D) for lower door assembly (easily removed for installation access).
- Special top required for ice machines weighing more than 454 kg (1000 lb). Add 5.38 cm (2.12") to height. Contact factory.
- Required clearance for installation access through doors (may require removal of door assembly).
- Follett recommends installation of a floor drain with grate with all ice storage bins. Consider cart positioning when locating the drain. Clearance required to pull cart from below bin — minimum 106.7 cm (42.00"), optimal 142.2 cm (56.00").
- Each cart holds 109 kg (240 lb) without optional Totes ice carriers, 68 kg (150 lb) with Totes ice carriers.
- Models offered with window only.
- Models offered with door assembly and SmartGATE only.

ITS Series

