

230 V/50 Hz and 220 V/60 Hz  
Installation, Operation and Service Manual  
Serial numbers E01087 to K46456

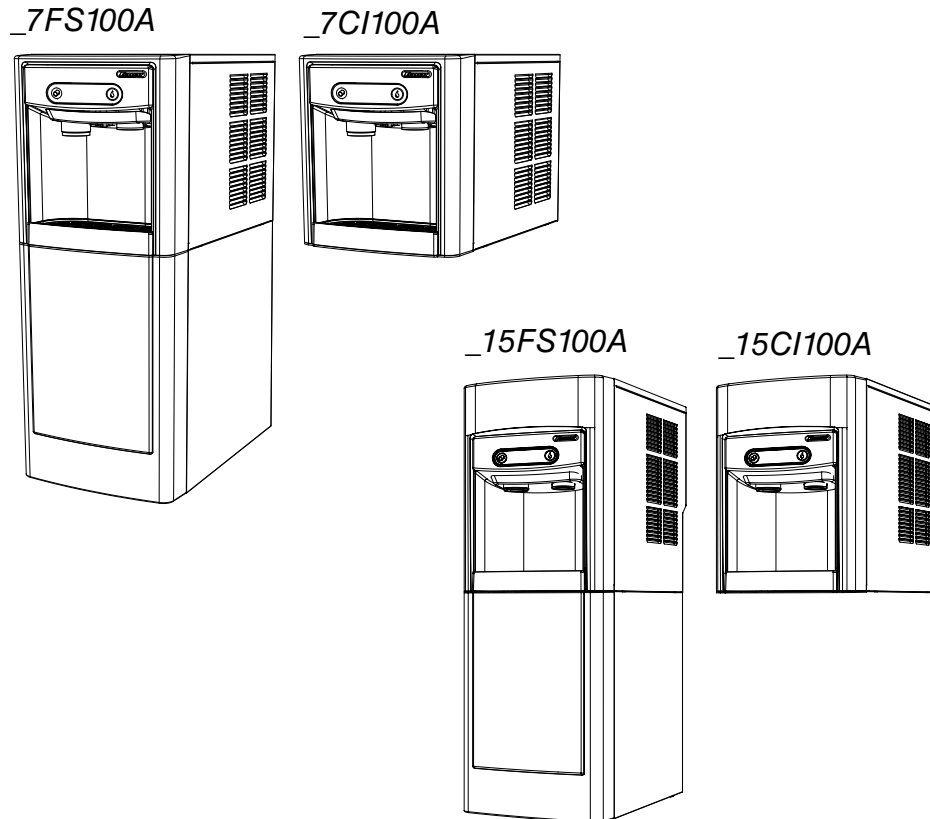

## Welcome to Follett

Follett equipment enjoys a well-deserved reputation for excellent performance, long-term reliability and outstanding after-the-sale support. To ensure that this equipment delivers that same degree of service, review this guide carefully before you begin your installation.

Should you need technical help, please call our Technical Service group at (877) 612-5086 or (610) 252-7301.

Please have your model number, serial number and complete and detailed explanation of the problem when contacting Technical Service.

## Getting Started

After uncrating and removing all packing material, inspect the equipment for concealed shipping damage. All freight is to be inspected upon delivery. If visible signs of damage exist, please refuse delivery or sign your delivery receipt "damaged." Follett Customer Service must be notified within 48 hours. Wherever possible, please include detailed photos of the damage with the original packaging so that we may start the freight claim process.

# Contents

<b>Welcome to Follett</b> .....	<b>1</b>
Getting Started .....	1
<b>Before You Begin</b> .....	<b>3</b>
<b>Specifications</b> .....	<b>4</b>
Dimensions .....	4
Ambient Information .....	4
Plumbing .....	4
<b>Specifications</b> .....	<b>5</b>
Water .....	5
Clearances .....	5
Electrical .....	5
Refrigeration .....	5
Heat Rejection .....	5
_7 Series Detailed Drawing .....	6
_15 Series Detailed Drawing .....	7
<b>Installation</b> .....	<b>8</b>
Countertop Installation .....	8
Freestanding Installation .....	9
<b>Maintenance/Cleaning Mode</b> .....	<b>12</b>
<b>Accessing Internal Components</b> .....	<b>12</b>
<b>Filter Display Indicator Activation</b> .....	<b>13</b>
<b>Cleaning and Sanitizing Procedure</b> .....	<b>14</b>
<b>Service</b> .....	<b>15</b>
LED Indicator Description .....	15
Evaporator Disassembly .....	16
Evaporator Assembly .....	19
Water Feed Schematic .....	23
Bin Melt Water/Evaporator Feed/Clean Out System Schematic .....	24
Vent System Schematic .....	24
Refrigeration Schematic .....	25
Condenser Fan Motor Removal (_7 Series Shown) .....	26
User Interface Display Identification .....	27
Electrical Wiring Diagram .....	29
<b>Parts</b> .....	<b>30</b>
_7 Series Exterior .....	30
_7 Series Interior .....	32
_15 Series Exterior .....	34
_15 Series Interior .....	36
_7 Series Bin Assembly .....	38
Evaporator Assembly .....	42
Base Stand .....	44

## Before You Begin

If needed, the serial number of your dispenser can be found by removing the drip tray ❶ and locating the serial number label ❷. A QR Code is located on the right hand side of the drip tray ❸. This code allows you to access manuals, technical bulletins, and on-line training related to the 7 Series and 15 Series dispensers.

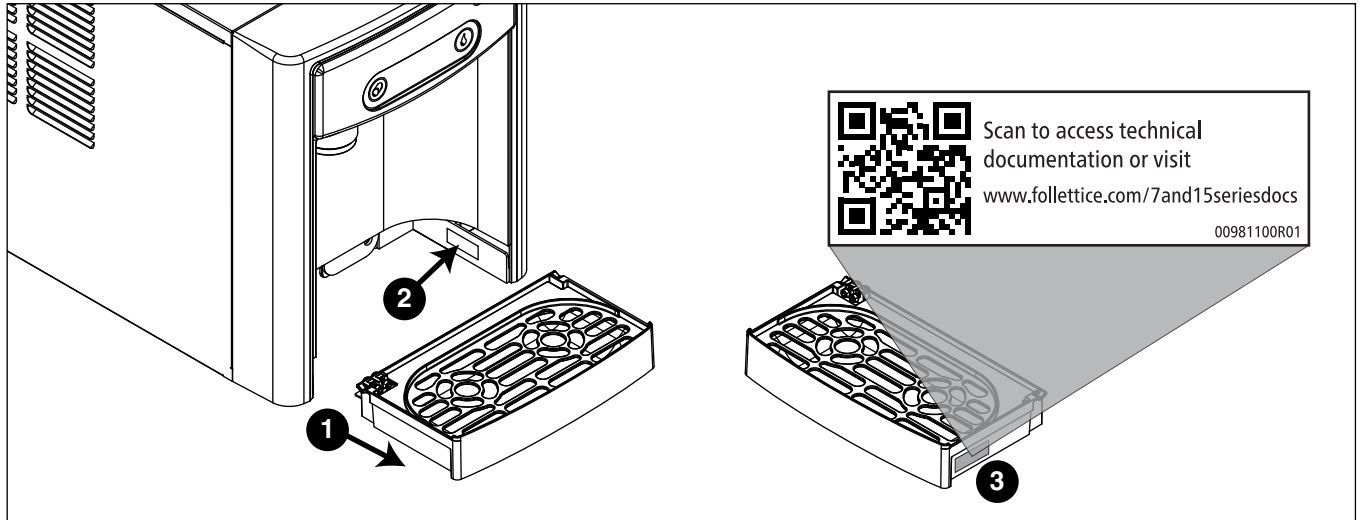

Check your paperwork to verify that you received the correct dispenser. Follett configuration numbers are designed to provide information about the type of dispenser you are receiving. The following is an explanation of the different model numbers.

<b>E</b>	<b>7</b>	<b>CI</b>	<b>100</b>	<b>A</b>
<b><u>Electrical</u></b>	<b><u>Dispenser Storage Capacity</u></b>	<b><u>Configuration</u></b>	<b><u>Ice Machine Capacity</u></b>	<b><u>Condenser Type</u></b>
E 230 V/50 Hz C 220 V/60 Hz	7 7 lb (3.1 kg) 15 15 lb (6.8 kg)	CI Countertop FS Freestanding	100 lb (45.3 kg) per day	A Air-cooled

## CAUTION!

- Do not tilt unit further than 30° off vertical during uncrating or installation.
- Dispenser bin area contains mechanical, moving parts. Keep hands and arms clear of this area at all times. If access to this area is required, power to unit must be disconnected first.
- This appliance is not suitable for installation in an area where a water jet could be used.
- This appliance must not be cleaned by a water jet.
- User maintenance should not be done by children.
- Follett recommends a Follett water filter system be installed in the ice machine inlet water line (standard capacity #00130229, high capacity #00978957, carbonless high capacity #01050442).
- Prior to operation clean the dispenser in accordance with instructions found in this manual.
- Do not block air intake or exhaust.
- This appliance should be permanently connected by a qualified person in accordance with application codes.
- A qualified person shall provide a readily accessible disconnect device incorporated into the fixed wiring.
- If the supply cord is damaged, it must be replaced by the manufacturer, its service agent or similarly qualified persons in order to avoid a hazard.
- This appliance can be used by children aged 8 years and above and persons with reduced physical, sensory, or mental capabilities, or lack of experience and knowledge if they have been given supervision or instruction concerning use of the appliance in a safe way and understand the hazards involved. Children should be supervised to ensure that they do not play with the appliance.
- This appliance is designed for commercial use.
- WARNING! To avoid a hazard due to instability of the appliance, it must be fixed in accordance with the instructions.
- Warranty does not cover exterior or outside installations.
- To reduce risk of shock, disconnect power before servicing.
- Connect to potable water supply only.
- Ice is slippery. Maintain counters and floors around dispenser in a clean and ice-free condition.
- Ice is food. Follow recommended cleaning instructions to maintain cleanliness of delivered ice.

## Specifications

### Dimensions

	_7CI100A	_7FS100A	_15CI100A	_15FS100A
Width	40 cm (14.50")	40 cm (14.50")	40 cm (14.50")	40 cm (14.50")
Depth	56.2 cm (22.12")	56.2 cm (22.12")	59.7 cm (23.50")	59.7 cm (23.50")
Height	44.5 cm (17.50")	106.4 cm (41.88")	57.2 cm (22.50")	118.7 cm (46.75")
Unit Shipping Weight	41 kg (90 lb)	54.4 kg (120 lb)	45.4 kg (100 lb)	60 kg (130 lb)

### Ambient Information

#### CAUTION!

The \_7CI100A, \_7FS100A and \_15CI100A, \_15FS100A are for indoor use only. Designed for commercial use. Follett is not able to provide in-house services for residential installations.

	Maximum*	Minimum*
Air Temperature†	38 C (100 F)	10 C (50 F)
Water Temperature	32.2 C (90 F)	4.5 C (40 F)
Water Pressure	70 psi (483 kpa)	69 kpa (10 psi)
Relative Humidity	55% at 25.5 (78 F)	

\* Use outside of these limitations is misuse and will void warranty.

† Best performance is achieved between 27 C (80 F) and 10 C (50 F).

### Plumbing

- Water Inlet: 1/4" MPT
- Optional Drain Accessory Kit (item# 00956375 or 00981977): 1/2" ID tubing
- Water shut-off recommended within 1.5 m (5 ft) of dispenser

# Specifications

## Water



### **WARNING!**

*Connect to potable water supply only.*

- Water Mineral Content:
  - TDS: greater than 5 ppm (mg/l) but less than 400 ppm (mg/l)
  - Hardness: Less than 200 mg/l (12 gpg)
- Not recommended for use with softened water
- Ingress Protection (IP) rating: IPX0 (no protection)

## Clearances

- 7.62 cm (3") behind and on each side of dispenser for electrical and connection and ventilation

## Electrical

- **E Series:** 230 V, 50 Hz, 1 phase, 5A, maximum fuse 10A
- **C Series:** 220 V, 60 Hz, 1 phase, 5A, maximum fuse 10A
- Connect to dedicated 10A circuit, fuse or breaker.
- Must be grounded - requires 3-prong outlet. Do not remove ground.
- Replacement cord instructions, type IEC 60320-C13 attachment - If the supply cord is damaged, it must be replaced by a special cord or assembly available from the manufacturer or its service agent.

## Refrigeration



### **WARNING!**

*Do not damage the refrigerant circuit. Refrigerant can cause personal injury and/or damage dispenser.*

- Refrigerant R134a – 204 grams (7.2 ounces)

## Heat Rejection

- 498 W (1700 BTU/hr)

# Specifications (continued)

## \_7 Series Detailed Drawing

### Countertop models

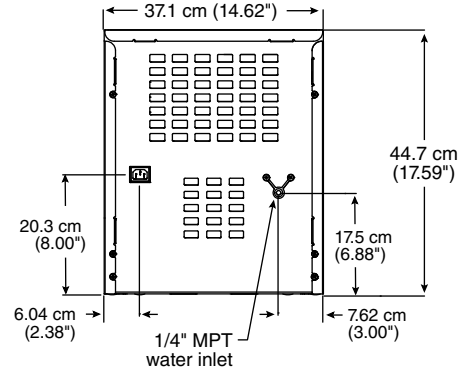
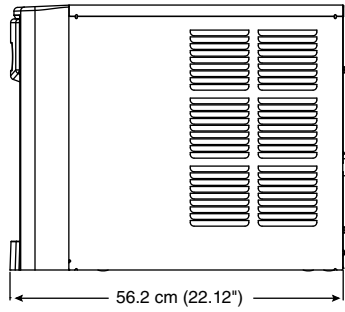
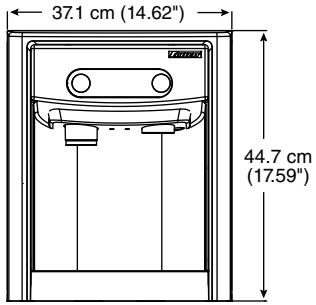

### Freestanding models

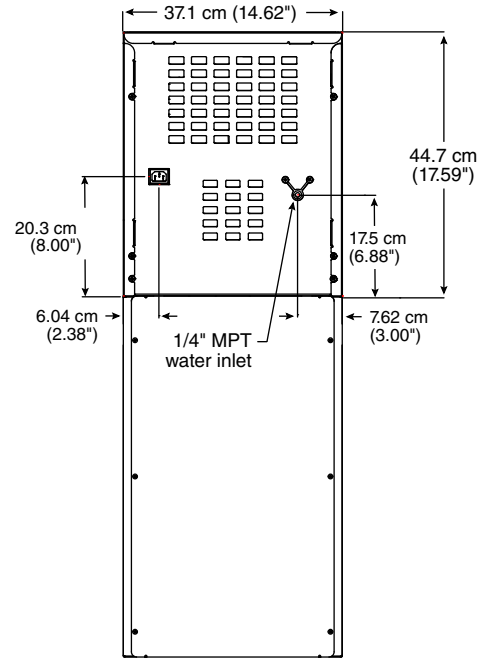
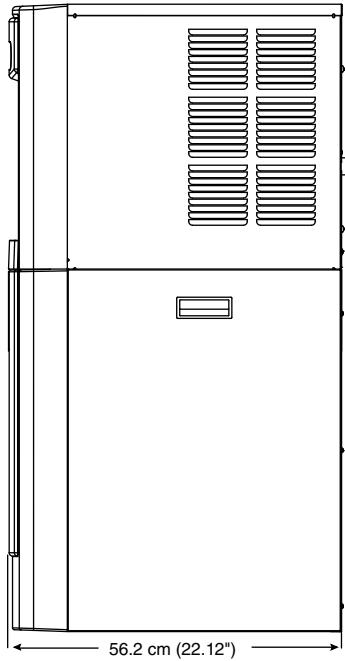
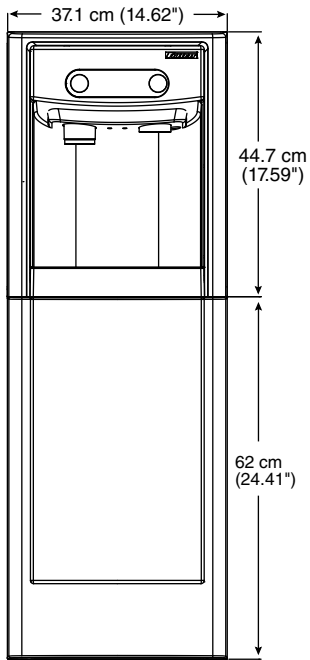

# Specifications (continued)

## \_15 Series Detailed Drawing

### Countertop models

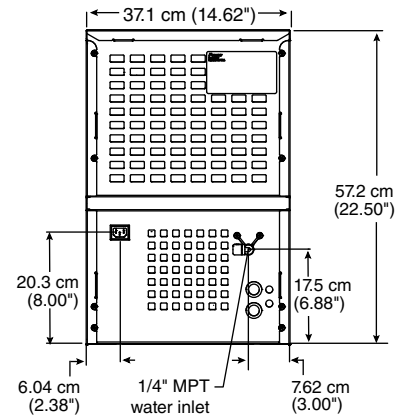
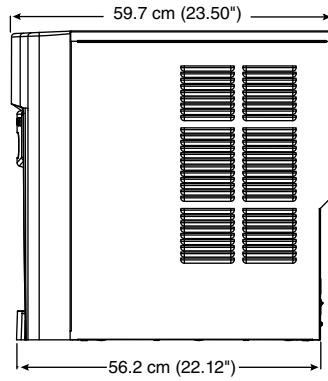
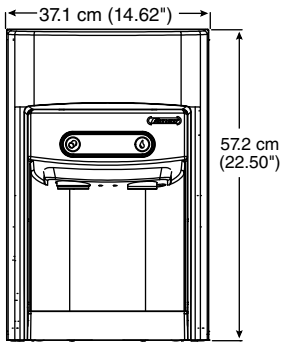

### Freestanding models

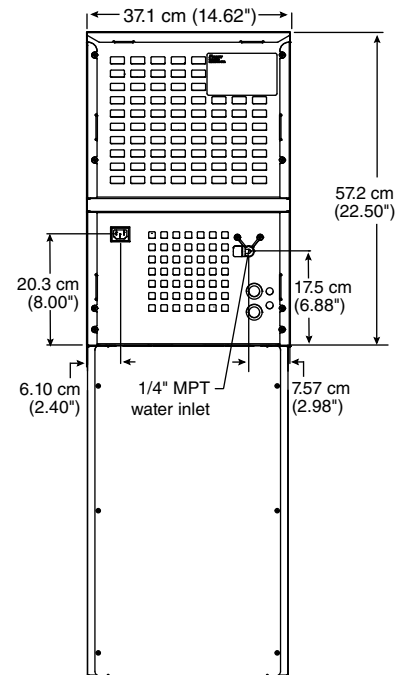
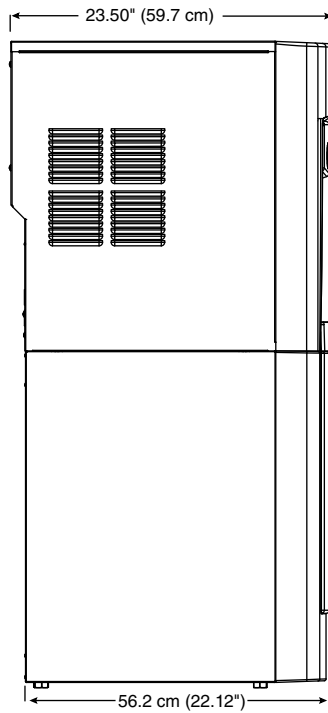
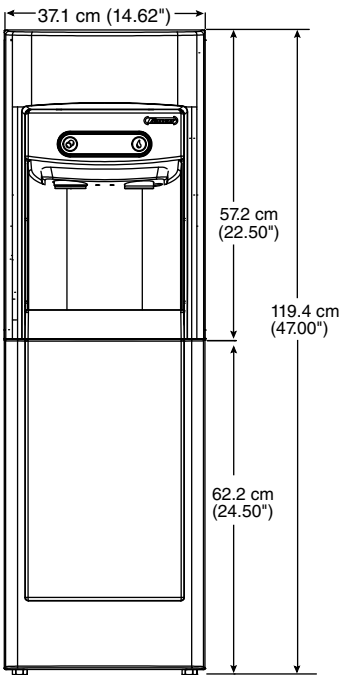

# Installation

## CAUTION!

No service or maintenance should be performed until the technician has thoroughly read this service manual. Except for routine cleaning and sanitizing, only qualified technicians should attempt to service or maintain this equipment.

## Countertop Installation

The \_7 Series countertop model is designed to fit on counters underneath standard mounted cabinets, this does not apply to \_15 Series models. See [page 4](#) for dimensions. Installation instructions for freestanding model may be found on [page 9](#).

1. A clearance of at least 7.62 cm (3") is required behind and on each side of the dispenser for electrical connection and ventilation (**Fig. 1**).
2. Rough-in the electrical service and water line.
  - Electrical: 230 V, single phase. The dispenser is provided with a 2.4 m (8 ft) power cord with choice of CEE 7/7, AS 3112, or BS 1363 plug.
  - Water: supply line (with shut-off valve) connects to the dispenser's 1/4" MPT inlet.

## NOTICE!

If installing optional Drip Tray Drain Kit or Leg Accessory, complete those steps before proceeding. Refer to instructions included with the Drip Tray Drain Kit, or see [page 9](#) for Leg Accessory instructions.

3. Connect water line. Recommended routing (**Fig. 2**) allows easy access to water for cleaning and sanitizing procedure.
4. If installing the optional internal water filter\*, please see [Maintenance/Cleaning Mode on page 12](#) before proceeding. If not, proceed to step 5.
  - \* If your dispenser has the internal water filter option, the water filter *must* be installed for the dispenser to operate. Because internal components will need to be accessed for both procedures, Follett recommends installing the water filter just prior to initial sanitizing.
5. Connect power supply.
6. Sanitize the dispenser prior to use (see the Initial Sanitizing Kit instructions shipped with this unit).

Fig. 1

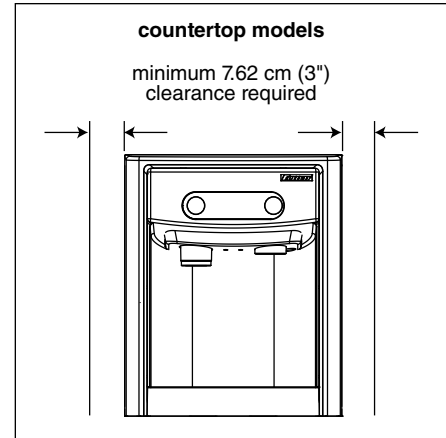
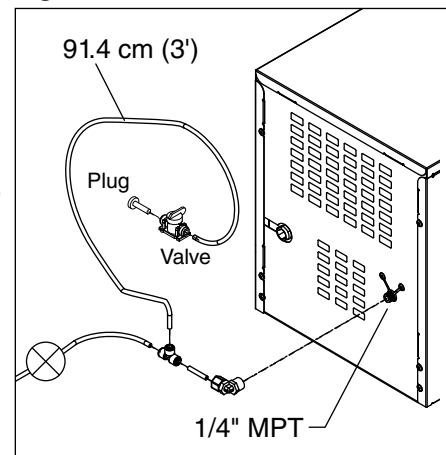

Fig. 2





## Optional Leg Accessory Installation

### CAUTION!

Use caution when tipping the dispenser during leg installation. Do not lay unit on back or side. **DO NOT EXCEED 30°** angle. Tipping more than 30° can result in compressor malfunction.

1. If installing optional 4" Leg Accessory (item# 00956300), place a 12.7 cm (5") spacer underneath the dispenser to ease installation.
2. Remove four plastic, thread-protecting plugs from bottom of dispenser.
3. Screw each leg into chassis (**Fig. 3**).

Fig. 3

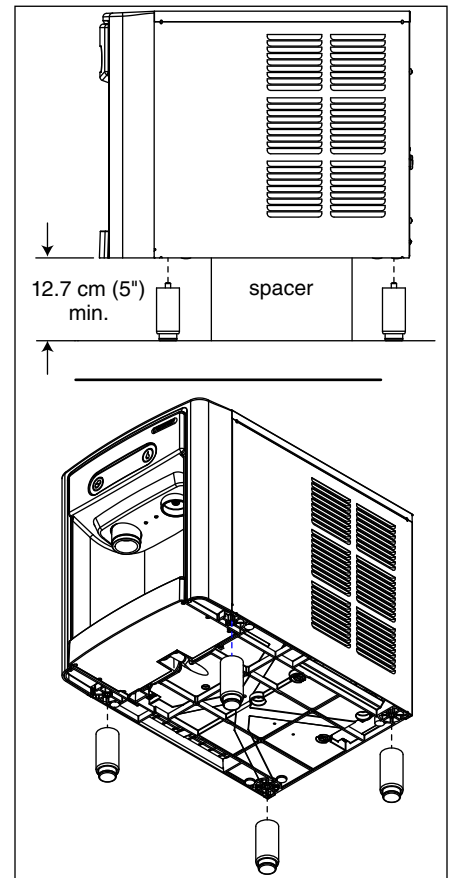

## Freestanding Installation

Installation instructions for countertop model may be found on [Countertop Installation on page 8](#).

1. A clearance of at least 3" (7.62 cm) is required behind and on each side of the dispenser for electrical connection and ventilation (**Fig. 4**).
2. Rough-in the electrical service and water line.
  - Electrical: 230V, single phase. The dispenser is provided with an 2.4 m (8 ft) power cord with choice of CEE 7/7, AS 3112, or BS 1363 plug.
  - Water: supply line (with shut-off valve) connects to the dispenser's 1/4" MPT inlet.

### NOTICE!

If installing optional Leg Accessory, complete those steps before proceeding. See [page 11](#) for Leg Accessory instructions.

Fig. 4

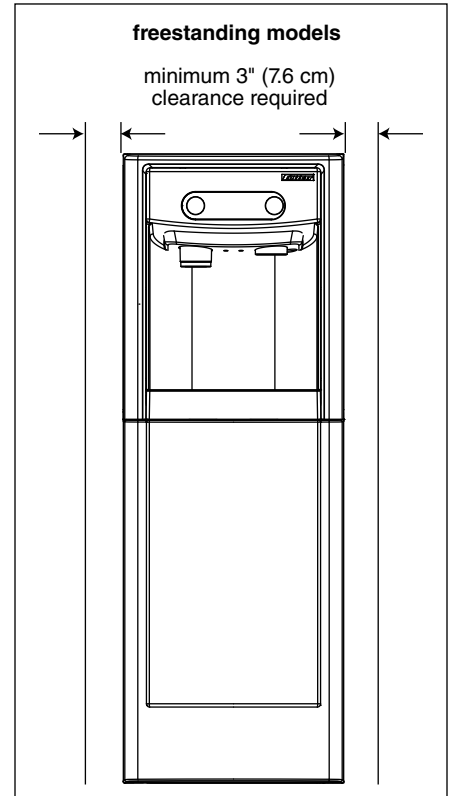

3. Remove four plastic, thread-protecting plugs from bottom of dispenser.
4. Attach dispenser to base stand with supplied hardware (**Fig. 5**).

**NOTICE!**

*If installing optional Drip Tray Drain Kit, refer to instructions included with the Drip Tray Drain Kit.*

**Fig. 5**

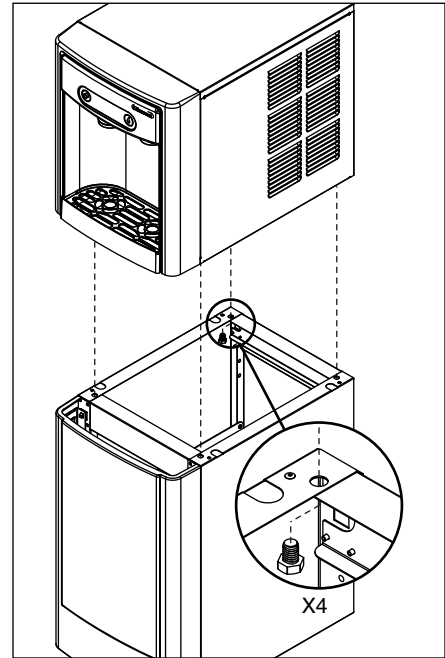

5. Connect water line. Recommended routing (**Fig. 6**) allows easy access to water for cleaning and sanitizing procedure.
6. If installing the optional internal water filter\*, please see **Optional Internal Water Filter Installation on page 11** before proceeding. If not, proceed to step 7.
  - \* If your dispenser has the internal water filter option, the water filter *must* be installed for the dispenser to operate. Because internal components will need to be accessed for both procedures, Follett recommends installing the water filter just prior to initial sanitizing.
7. Connect power supply.
8. Sanitize the dispenser prior to use (see the Initial Sanitizing Kit instructions shipped with this unit).

**Fig. 6**

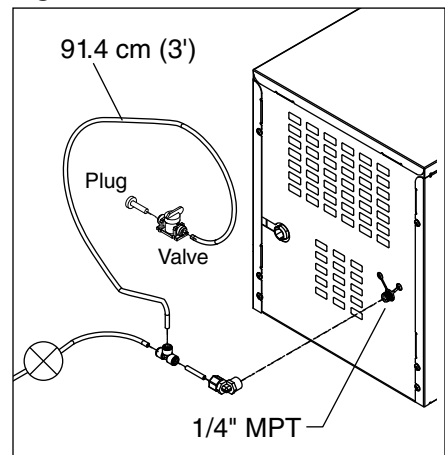

9. Secure unit to wall or cove molding with supplied bracket (**Fig. 7**) to prevent tipping.

**Note:** Fasteners must be supplied by installer.



**WARNING!**

*Freestanding unit must be secured to wall to prevent tipping. Failure to do could result in personal injury or damage to the unit.*

**Fig. 7**

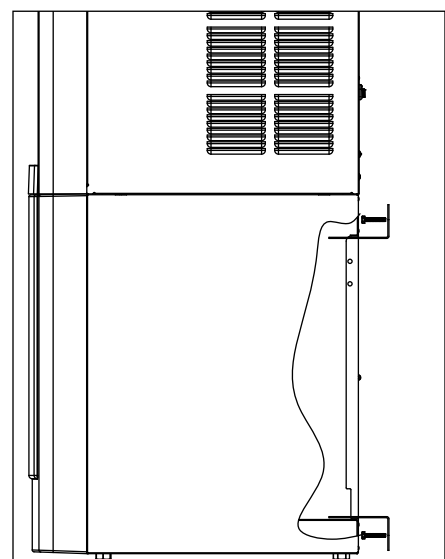

### Optional Leg Accessory Installation

1. If installing optional 6" Leg Accessory (item# 00956318), tilt or lay base stand on side and screw each leg into stand (**Fig. 8**).

**Fig. 8**

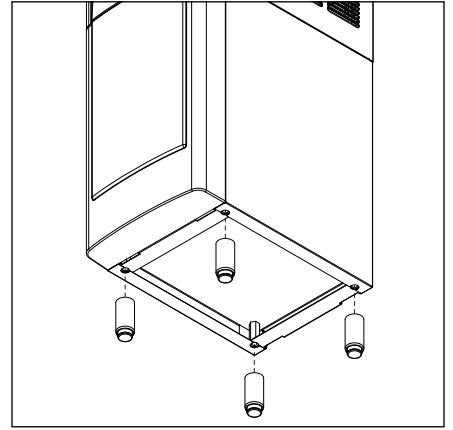

### Optional Internal Water Filter Installation

If your dispenser has the internal water filter option, the water filter *must* be installed for the dispenser to operate. Because internal components will need to be accessed for both procedures, Follett recommends installing the water filter just prior to initial sanitizing.

1. If installing the optional internal water filter, please complete the steps shown in [Accessing Internal Components on page 12](#) before proceeding.
2. Lift and remove the top panel, set aside (**Fig. 9.1**).
3. Remove two screws (**Fig. 9.2**) and remove left side panel.
4. Install filter as shown. Turn filter clockwise until it is fully seated (**Fig. 9.3**).

**Fig. 9**

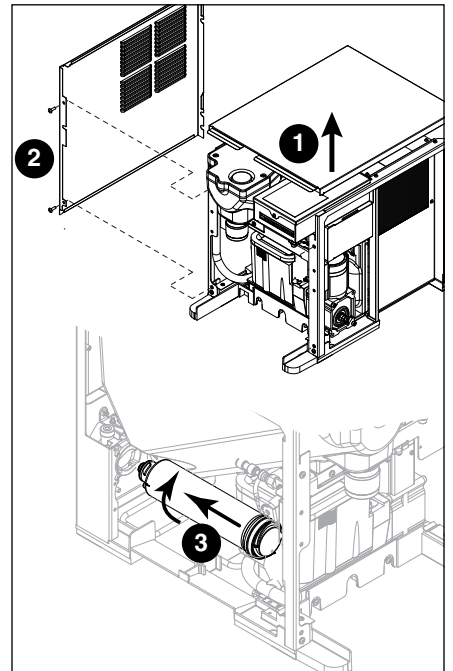

## Maintenance/Cleaning Mode



### Cleaning Mode (Dispensing Disabled) - Use when cleaning surface

Entering Cleaning Mode disables the User Interface and allows you to clean the outside of the dispenser without accidentally dispensing water or ice.

1. To enter Cleaning Mode, press and immediately release the maintenance/clean switch (**Fig. 10.1**) so that only "FRESH FILTERED ICE AND WATER" displays in the user interface (**Fig. 10.2**).
2. To exit Cleaning Mode, press and immediately release the maintenance/clean switch so that the ice and water icons also display in the user interface.

### Maintenance Mode (All Operations Disabled) - Use when cleaning ice machine

Entering Maintenance Mode disables all operations and allows you to safely clean and/or sanitize the ice machine and dispenser.

1. To enter Maintenance Mode, press and hold the maintenance/clean switch (**Fig. 10.3**) until  displays in the user interface (**Fig. 10.4**).
2. To exit Maintenance Mode, press and hold the maintenance/clean switch until  no longer displays in the user interface.

**Note:** Entering and exiting Maintenance Mode will reset the six-month periodic maintenance reminder.

Fig. 10

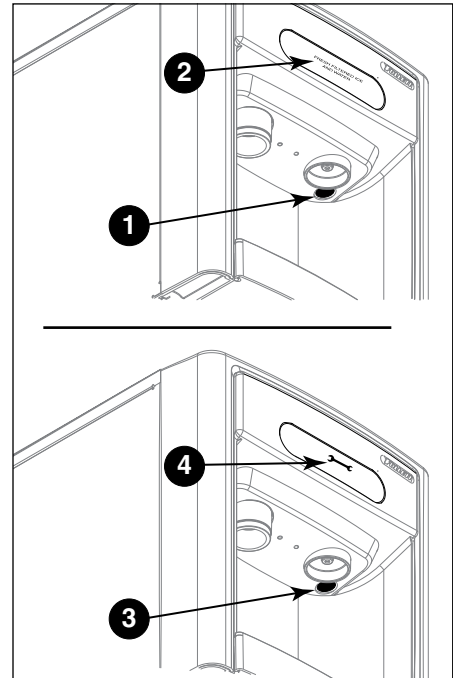

## Accessing Internal Components

### CAUTION!

*Except for routine cleaning and sanitizing, only qualified technicians should attempt to service or maintain this equipment.*

1. Press and hold the maintenance/clean switch (**Fig. 10.1**) until  displays in the user interface (**Fig. 10.2**).
2. Remove (unscrew) chrome ice dispenser chute (**Fig. 11.1**).
3. Remove the drip tray (**Fig. 11.2**).
4. Remove the two screws (**Fig. 11.3**) on the front panel (behind the drip tray).
5. Remove and set aside the front panel (**Fig. 11.4**). **Do not disengage the plug on the back of the User Interface or the tubing at the water dispenser chute (if so equipped).**

Fig. 11



## Filter Display Indicator Activation

If you purchased your dispenser with a Follett filter, the filter display indicator activation has been preset at the factory.

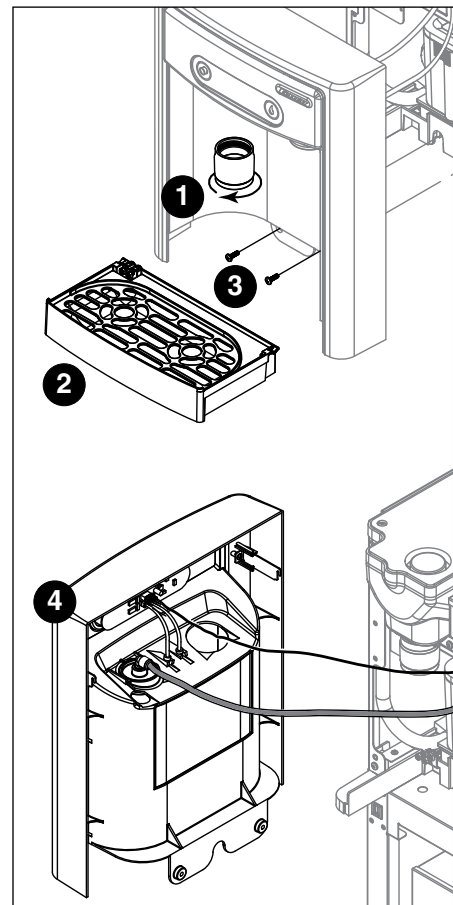
If you are using an “after market filter,” an adjustment may be made to activate the “Fresh Filtered Ice & Water” display.

### Activating “Fresh Filtered Ice & Water”

1. Remove the front panel as explained in [Accessing Internal Components on page 12](#) then refer to **Fig. 12**.
2. Remove top panel (**Fig. 12.1**).  
**Note:** For \_15 Series dispensers, the right side panel must also be removed.
3. Remove (1) screw and top of control board enclosure (**Fig. 12.2**).
4. Locate the DIP switches on the dispenser's control board (**Fig. 13**). Use a fine-pointed object to move the “Filter” DIP switch (DIP switch #3) to the ON position.

### Deactivating the Six-Month Maintenance/Filter Change Reminder

1. Use a fine-pointed object to move the “PM” DIP switch (DIP switch #8) to the ON position.

**Fig. 12**

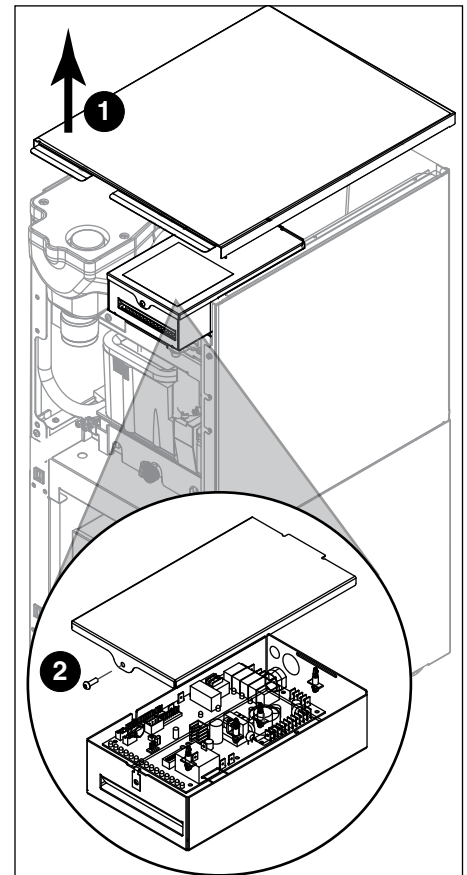

**Fig. 13**

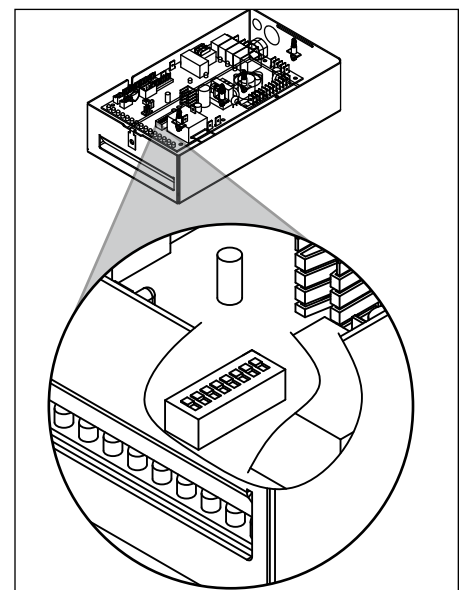

	OFF	ON	
Not used (OFF position)	<input type="checkbox"/>	<input checked="" type="checkbox"/>	1
Ice only	<input type="checkbox"/>	<input checked="" type="checkbox"/>	2
No internal filter	<input type="checkbox"/>	<input checked="" type="checkbox"/>	3
Not used (OFF position)	<input type="checkbox"/>	<input checked="" type="checkbox"/>	4
Not used (OFF position)	<input type="checkbox"/>	<input checked="" type="checkbox"/>	5
15 minute delay	<input type="checkbox"/>	<input checked="" type="checkbox"/>	6
Not used (OFF position)	<input type="checkbox"/>	<input checked="" type="checkbox"/>	7
Six-month PM enabled	<input type="checkbox"/>	<input checked="" type="checkbox"/>	8

Ice and water  
Internal filter supplied or to display "Fresh Filtered"  
30 minute delay  
Six-month PM disabled

## Cleaning and Sanitizing Procedure

Cleaning and sanitizing should be performed at least every 6 months (more often if local water conditions dictate).

### **WARNING!**

- Place the dispenser in Maintenance Mode prior to servicing or cleaning the ice machine. See [Maintenance/Cleaning Mode on page 12](#).
- For protection, rubber gloves and safety goggles (and/or face shield) should be worn when handling SafeCLEAN Plus™.
- Do not use bleach, it will damage the dispenser.

### Required Supplies

- **7 Series:** Follow the directions on the SafeCLEAN Plus packaging to mix 3 gal (11.4 L) of Follett SafeCLEAN Plus solution. Use 100 F (38 C) water.
- **15 Series:** Follow the directions on the SafeCLEAN Plus packaging to mix 6 gal (22.7 L) of Follett SafeCLEAN Plus solution. Use 100 F (38 C) water.
- Funnel, bucket, 100 F (38 C) potable water

### Ice machine and Dispenser

1. Dispense all the ice out of the unit.
2. Press and hold maintenance/clean switch until  displays in the user interface to enter Maintenance Mode.
3. Remove (unscrew) chrome ice dispense chute ([Fig. 14.1](#)).
4. Remove drip tray ([Fig. 14.2](#)).
5. Remove (2) screws located behind the drip tray ([Fig. 14.3](#)).
6. Move front panel and place on top or beside unit ([Fig. 14.4](#)).
7. Remove plug cap from the end of drain tube ([Fig. 14.5](#)) and lower tube to drain water into bucket. After the system has been drained of water replace plug cap in drain tube.
8. Secure tube in holder.
9. Remove cap from bin lid cover ([Fig. 14.6](#)).
10. Screw bin lid cover cap onto ice discharge chute ([Fig. 14.7](#)).
11. Pour SafeCLEAN Plus solution into bin lid access spout until solution reaches the spout neck.
12. Allow the SafeCLEAN Plus solution to remain in unit for 15 minutes.
13. While machine is cleaning, remove top and right side panel to access and clean air-cooled condenser.
14. Submerge ice dispense chute in the remainder of SafeCLEAN Plus solution for 2 minutes. Rinse with clean, potable water.
15. Drain system by lowering drain tube into bucket.
16. Secure drain tube into holder.
17. Fill and drain twice with potable water. Secure drain tube.
18. Place a bucket under the dispense chute and remove cap. **Note:** Some SafeCLEAN Plus solution will remain and drain out when cap is removed. Reposition cap on bin lid spout.
19. Reinstall front panel, ice dispense chute, and drip tray.
20. Press and hold maintenance/clean switch to exit Maintenance Mode.

Fig. 14



## User Interface and Exterior Cabinet

1. Press and release maintenance/clean switch so that only "FRESH FILTERED ICE AND WATER" displays in the user interface to enter Cleaning Mode (and disable dispensing).
2. Plastic parts, including the user interface, can be cleaned with a non-abrasive glass cleaner. Clean stainless steel panels with stainless steel cleaner.
3. Press and release maintenance/clean switch to put unit back into service.

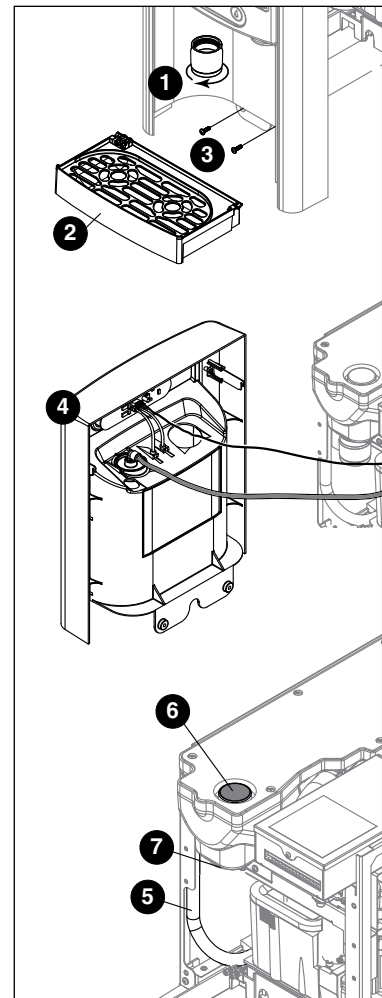
## Service

### LED Indicator Description

The LED Indicator is located behind the front panel.

Fig. 15



LED Name	LED Color	Description
Clean	Green	The dispenser is in Cleaning Mode. Dispenser is disabled to allow for cleaning of front panel. See <a href="#">Maintenance/Cleaning Mode on page 12</a> .
—	N/A	Not used.
PM	Red	Six-month periodic maintenance required.
Drip tray	Red	Drip tray full.
Water leak	Red	Internal leak in dispenser.
High amps	Red	Auger gearmotor has exceeded 0.55A. The HI amps and Time delay LEDs will illuminate, the machine will shut down for one hour, the LEDs will turn off, and the machine will resume normal operation.
Service	Red	8000 hour bushing check (call Follett technical service group at (877) 612-5086 or +1 (610) 252-7301).
Maintenance	Yellow	Enter Maintenance Mode by pressing and holding maintenance/clean switch for 5 seconds. Unit will not make or dispense ice.
Low water	Yellow	Insufficient water supply to machine or no low bin LED upon startup.
Time delay	Yellow	Ice production will not resume for at least 15 minutes after a full bin is achieved and a minimum amount of dispense activity has elapsed.
Sleep cycle	Green	After a full bin and 10 minutes of non-use, the unit goes into standby and will not produce ice until either: _7 Series: 12 hours has elapsed, _15 Series: 4 hours has elapsed or ice or water has dispensed.
Making ice	Green	Gearmotor, compressor, and fan motor energized.
Low bin	Green	Bin switch closed calling for ice.
Power on	Green	Power supplied to unit.

## Evaporator Disassembly

1. Disconnect power from the dispenser.
2. Turn off water supply to dispenser.
3. Remove (unscrew) chrome ice dispenser chute (Fig. 16.1).
4. Remove the drip tray (Fig. 16.2).
5. Remove the two screws (Fig. 16.3) on the front panel (behind the drip tray).
6. Remove and set aside the front panel (Fig. 16.4) - **do not disengage the plug on the back of the User Interface.**
7. Lift and remove the top panel, set aside (Fig. 16.5).
8. Remove two screws (Fig. 16.6) and remove left side panel.
9. Remove two screws (Fig. 16.7) and remove right side panel.

Fig. 16

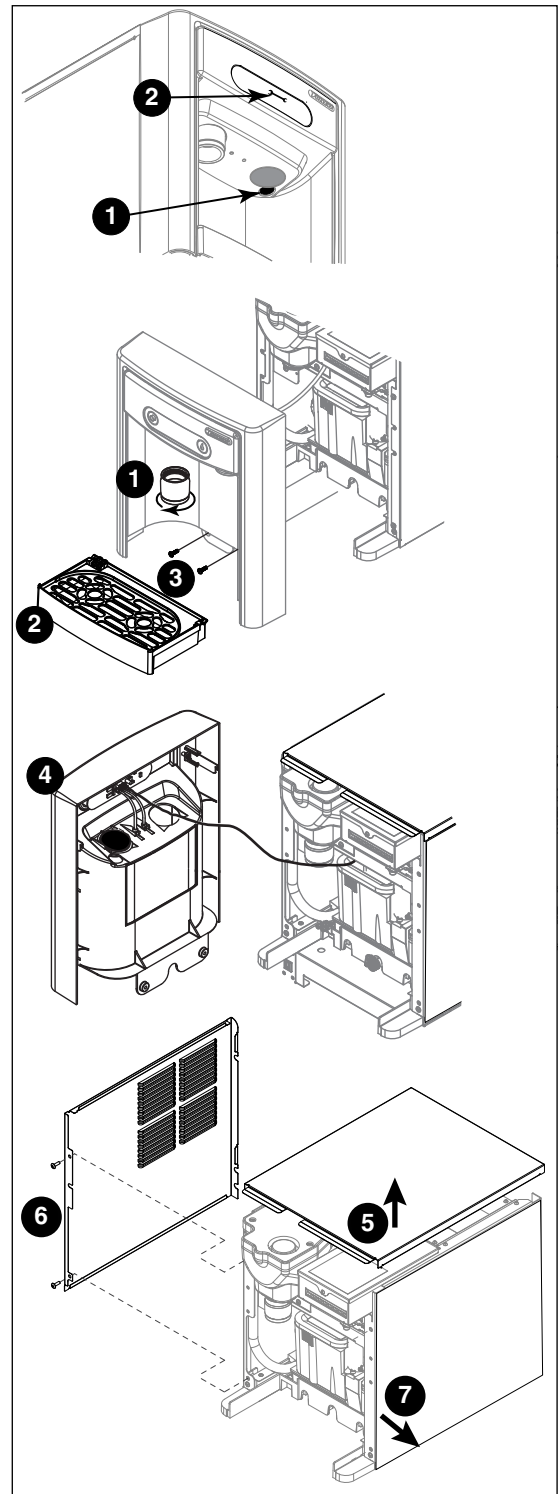



10. Unplug the gear motor (three connectors) (Fig. 16).

11. Remove ground screw connection.

12. Remove gear motor:

- Remove M6 allen screw, retainer, spacer and key (Fig. 18.1).
- Remove two M6x90 allen screws (Fig. 18.2).
- Pull gear motor from auger (Fig. 18.3).
- Remove main housing insulation (Fig. 18.4).

13. Remove all traces of Petrol-gel from auger shaft.

14. Remove compression nozzle:

- Loosen hose clamp (Fig. 19.1).
- Remove transport tube (Fig. 19.2).

Fig. 17

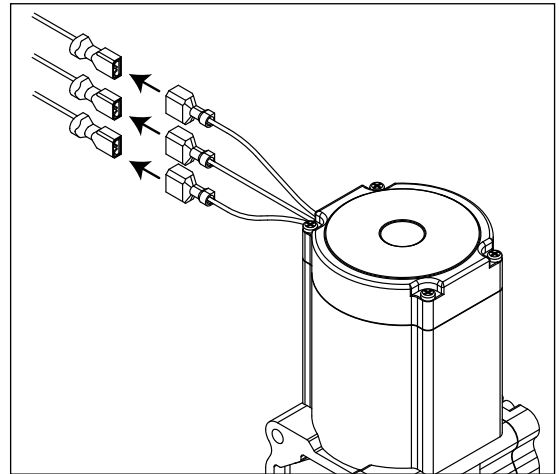

Fig. 18

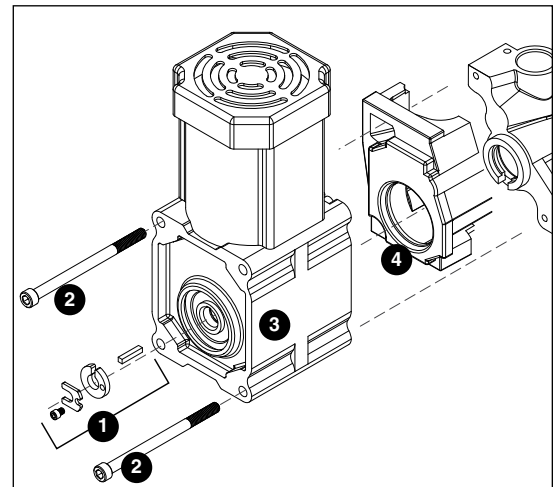
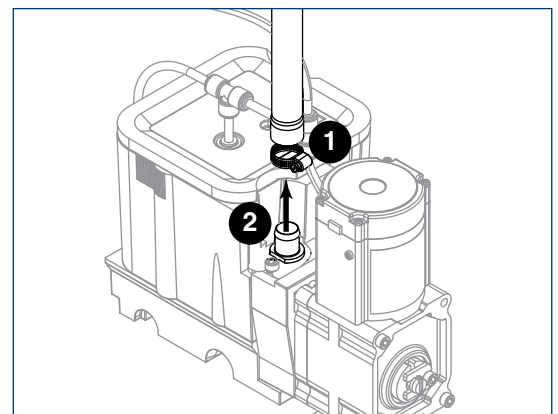
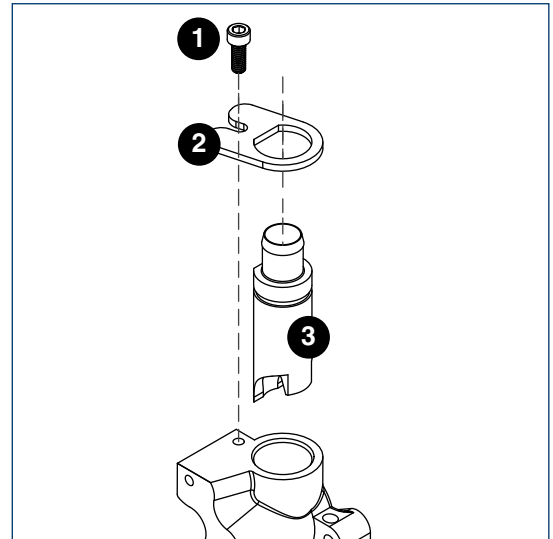

Fig. 19



15. Remove M6 socket head allen screw (Fig. 20.1).
16. Remove compression nozzle retainer (Fig. 20.2).
17. Remove compression nozzle (Fig. 20.3).

Fig. 20



18. Remove main housing:
  - Disconnect vent line from T fitting (Fig. 21.1).

Fig. 21

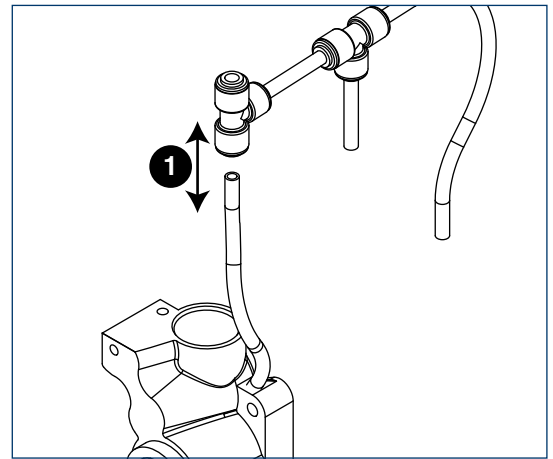

19. Remove three M6x25 socket head allen screws (Fig. 22.1).
20. Remove main housing (Fig. 22.2).

Fig. 22

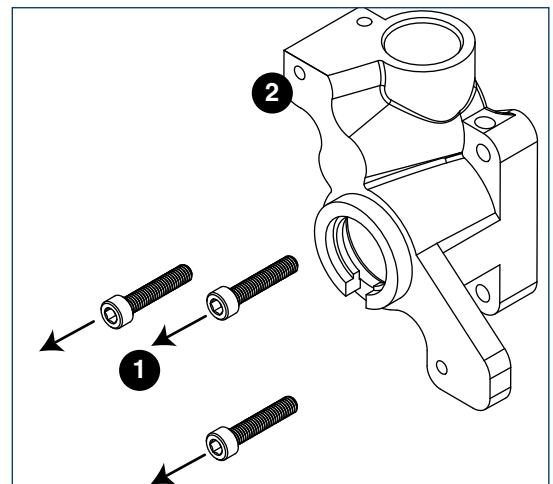

21. Remove and discard mating ring and seal (**Fig. 23.1**).
22. Carefully remove auger (**Fig. 23.2**).



**WARNING!**

*Use caution when removing auger. The auger is very sharp - handle with care to avoid personal injury.*

### Evaporator Assembly

1. Remove and inspect main housing O-ring seal. Replace if damaged in any way.
2. Clean O-ring groove. Lubricate O-ring with Petrol-gel and reinstall.
3. Use cardboard disc to press new mating ring into main housing (**Fig. 24.1**).
4. Lube the shaft with liquid soap in the area shown (**Fig. 24.2**) and slip on seal and spring (**Fig. 24.3**).
 

**Note:** Do not touch the sealing surfaces with bare hands. Contact with bare skin will cause premature seal failure.
5. Install auger (**Fig. 24.4**).
6. Install main housing:
  - Slide main housing onto auger shaft (**Fig. 25.1**).
  - Install three M6x25 allen screws (**Fig. 25.2**).
  - Connect vent line to T fitting (**Fig. 25.3**).

**Fig. 23**

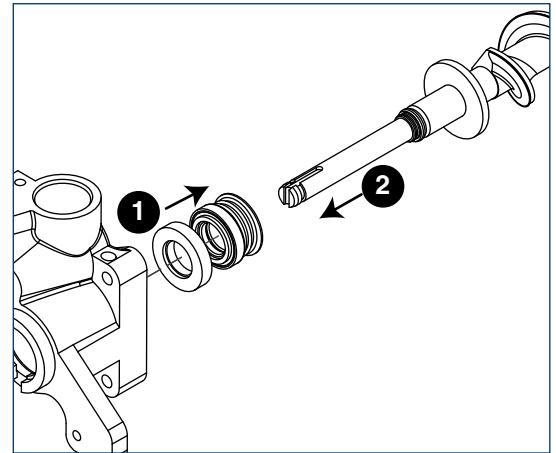

**Fig. 24**

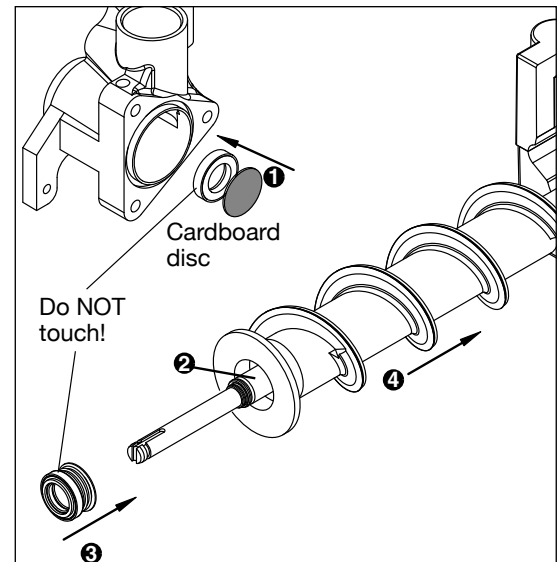

**Fig. 25**

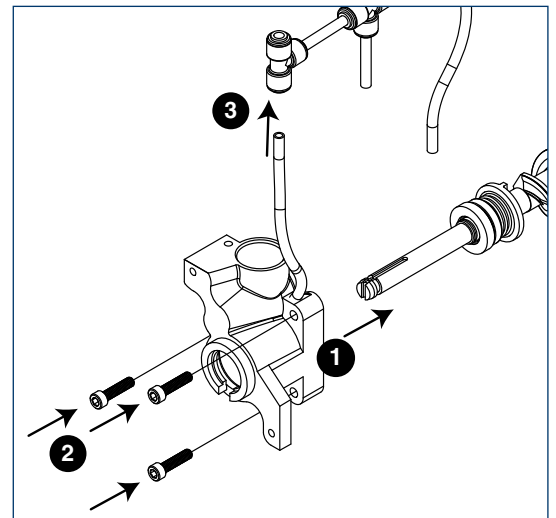

7. Install compression nozzle:

- Remove and inspect compression nozzle O-ring seal. Replace if damaged in any way.
- Clean O-ring groove. Lubricate O-ring with Petrol-gel and reinstall.
- Install compression nozzle (**Fig. 26.1**).
- Install compression nozzle retainer (**Fig. 26.2**).
- Install M6 socket head allen screw (**Fig. 26.3**).

Fig. 26

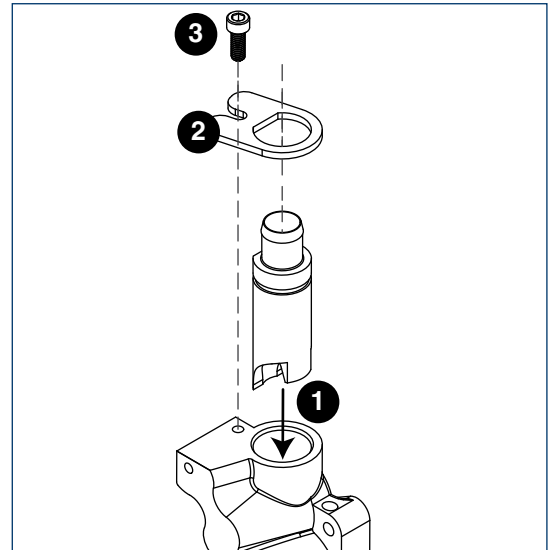

8. Install transport tube (**Fig. 27.1**).

9. Tighten hose clamp (**Fig. 27.2**).

Fig. 27

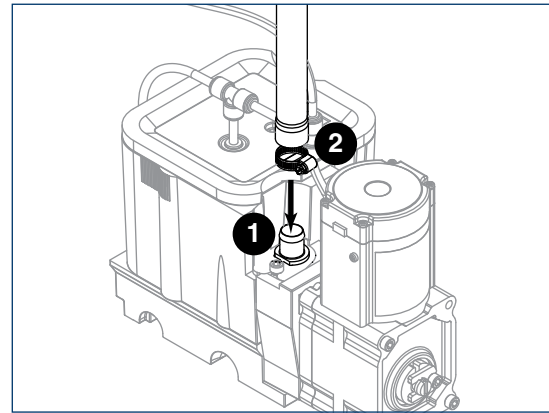

10. Install gear motor:

- Install main housing insulation (**Fig. 28.1**).
- Slide gear motor onto auger shaft (**Fig. 28.2**).
- Install two M6x90 allen screws (**Fig. 28.3**).

Fig. 28

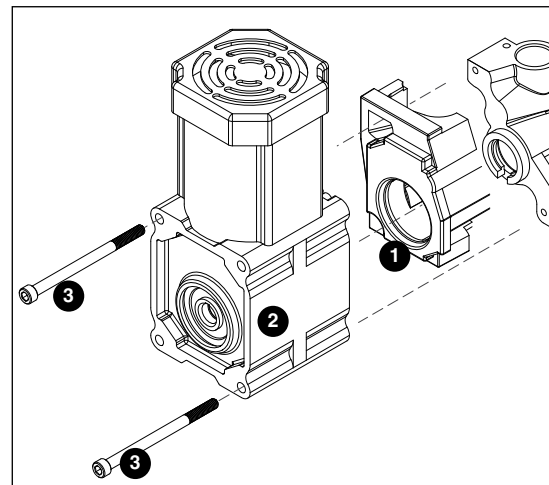

11. Use screwdriver to orient auger shaft to align with motor shaft keyway (**Fig. 29.1**).
12. Install key into keyway (**Fig. 29.2**).

**Fig. 29**

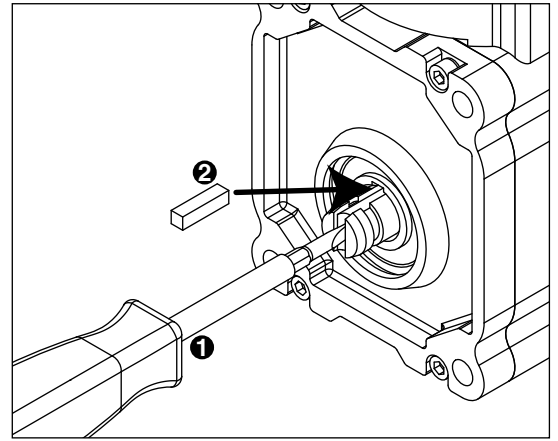

13. Install spacer, ensure that key is captured in slot (**Fig. 30.1**)

**Fig. 30**

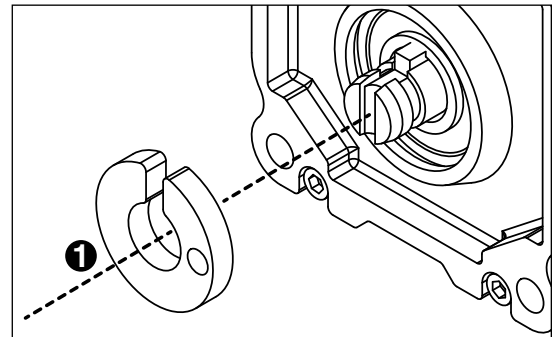

14. Insert screwdriver into groove of auger shaft and pry shaft outwards (**Fig. 31.1**).
15. Insert retainer into groove (**Fig. 31.2**), ensure that retainer is aligned with hole in spacer.

**Fig. 31**

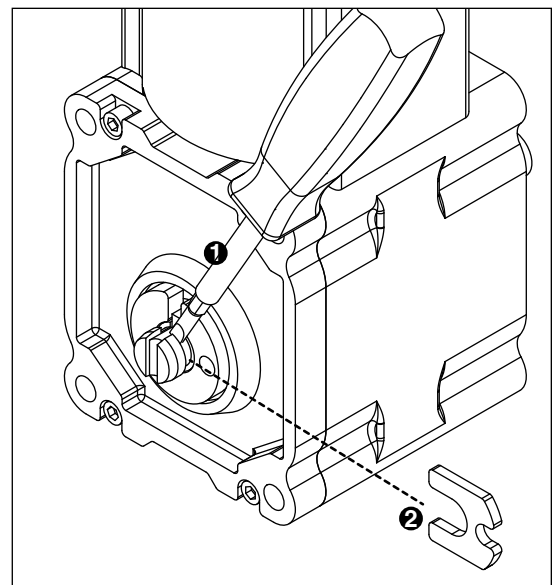

16. Install screw and tighten (**Fig. 32.1**).

**Fig. 32**

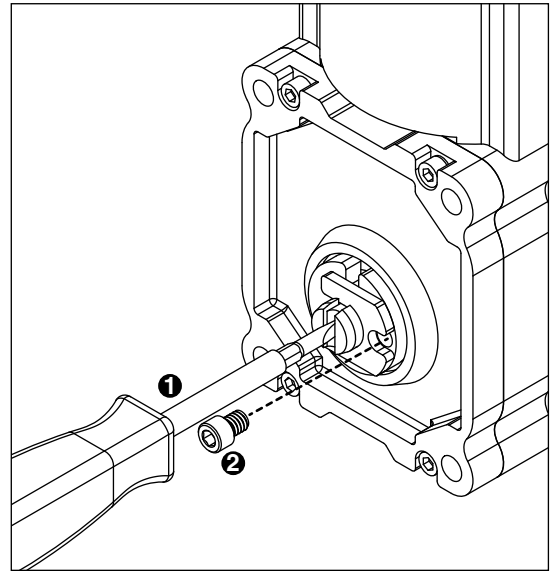

17. Plug in gear motor (**Fig. 33**).

- PINK to BLUE
- BLACK to BLACK
- GREY to WHITE
- Connect ground wire with ground screw.

**Fig. 33**

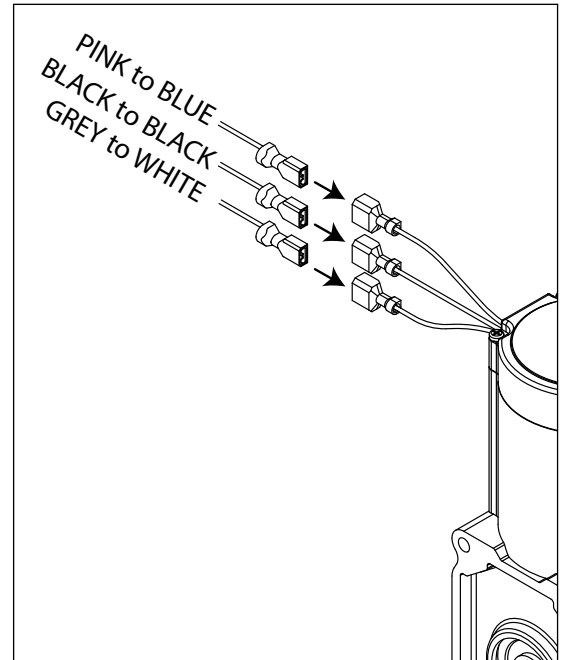

# Water Feed Schematic

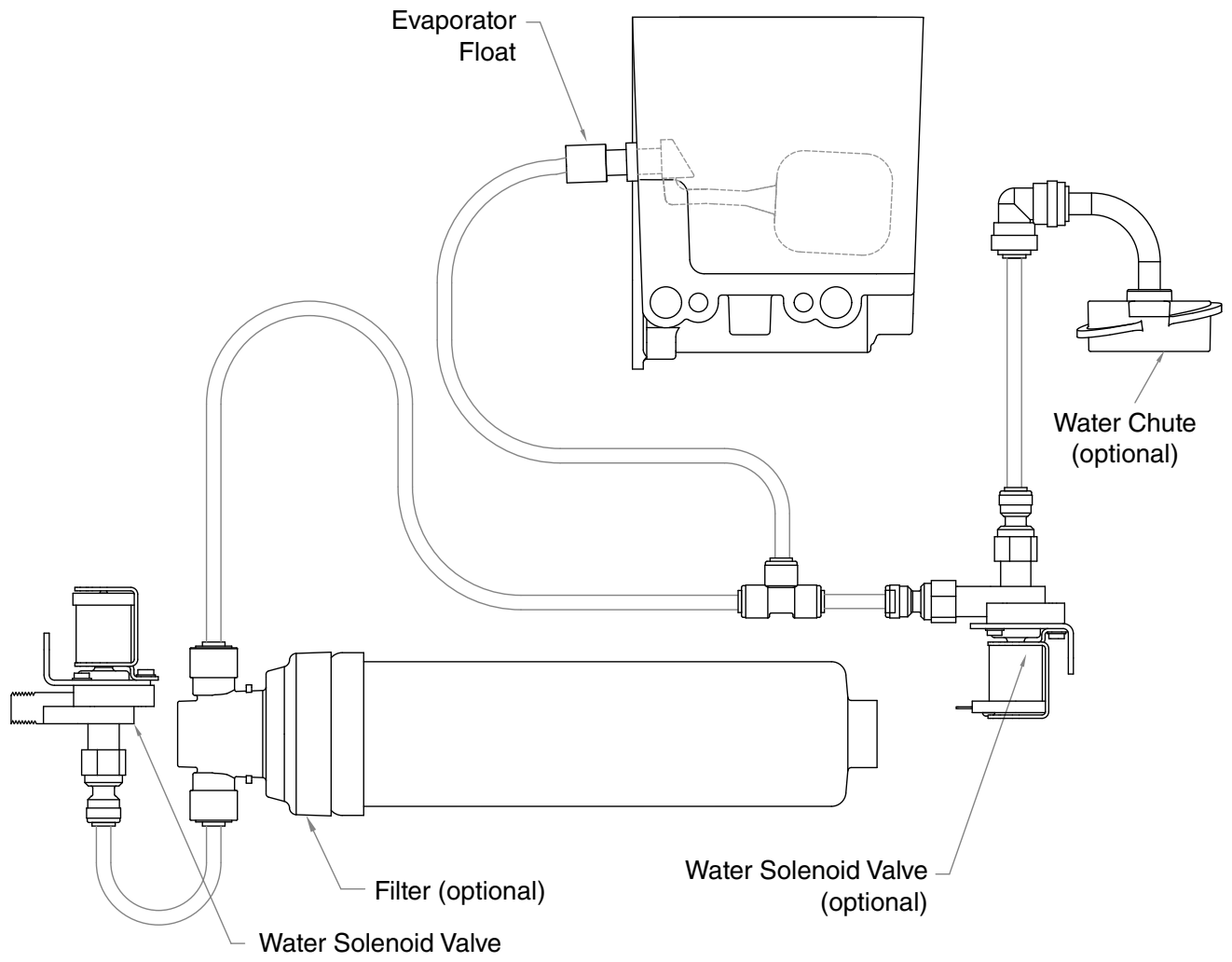

## Bin Melt Water/Evaporator Feed/Clean Out System Schematic

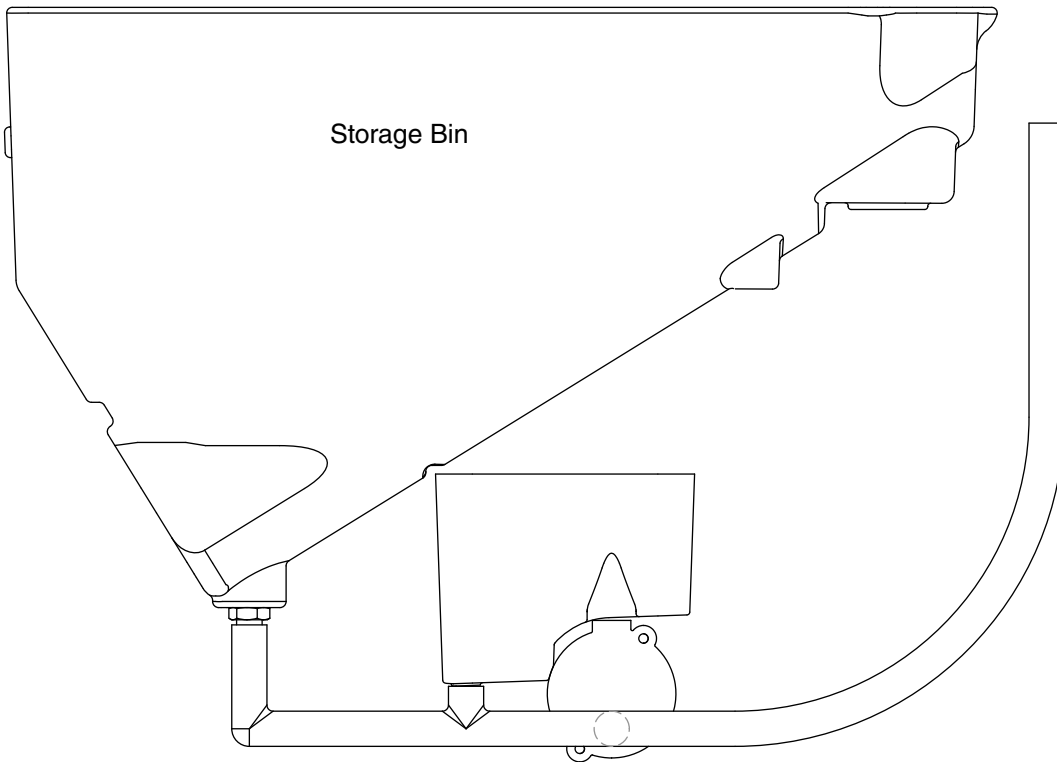

## Vent System Schematic

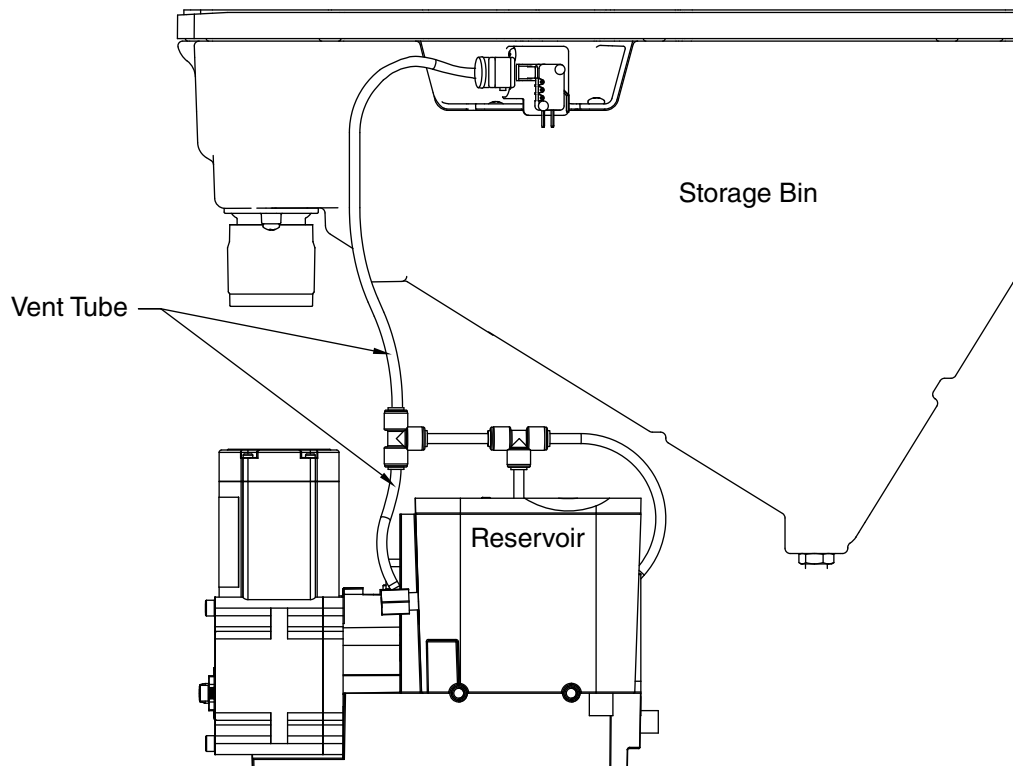



# Refrigeration Schematic

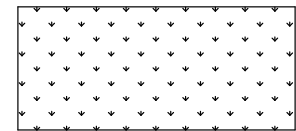
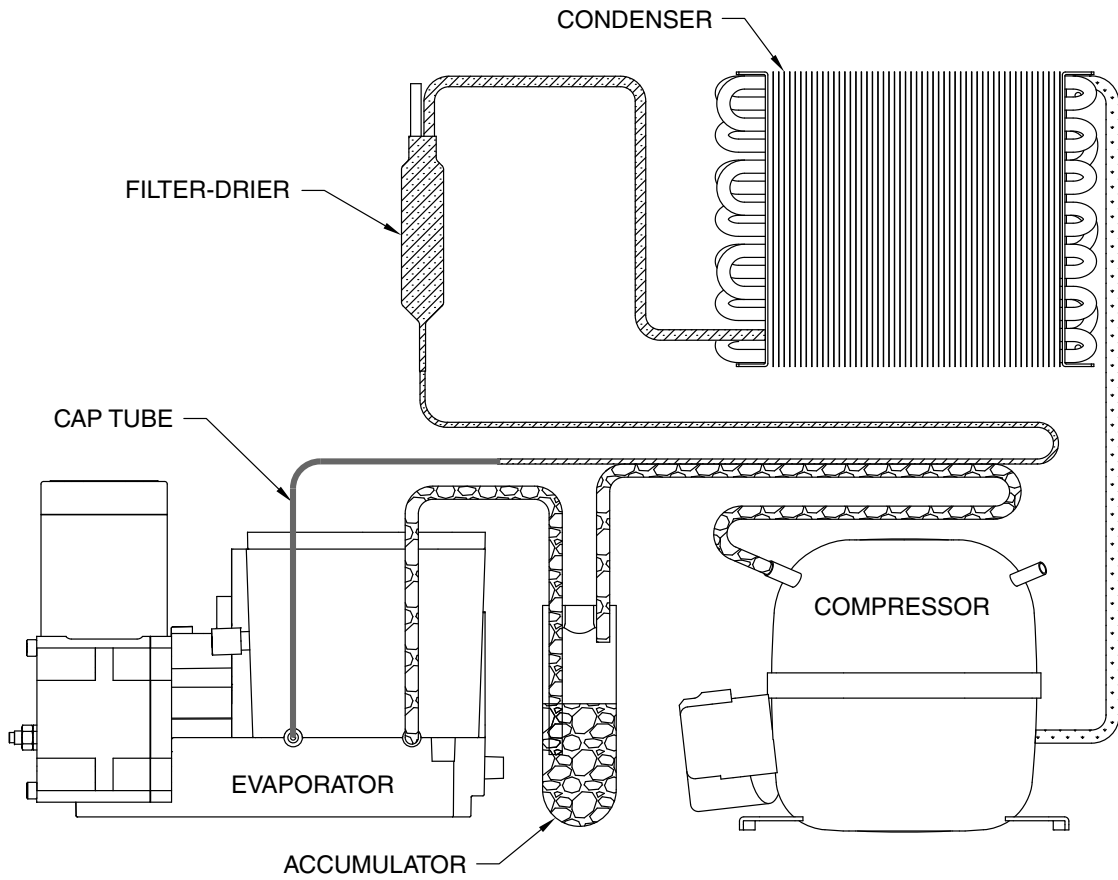

HIGH PRESSURE VAPOR



LOW PRESSURE LIQUID

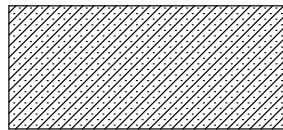

HIGH PRESSURE LIQUID

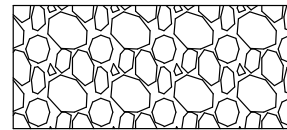





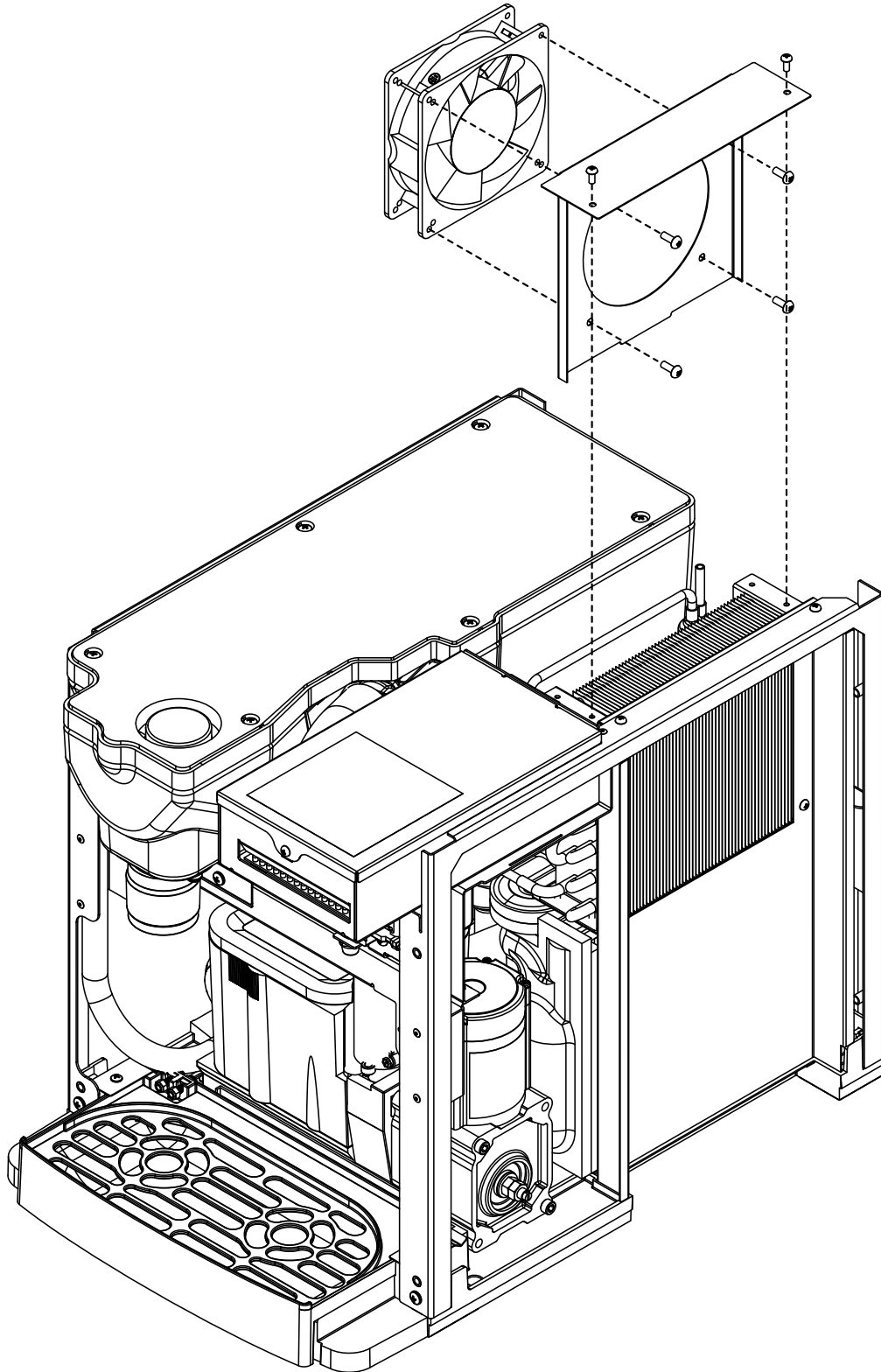

LOW PRESSURE VAPOR

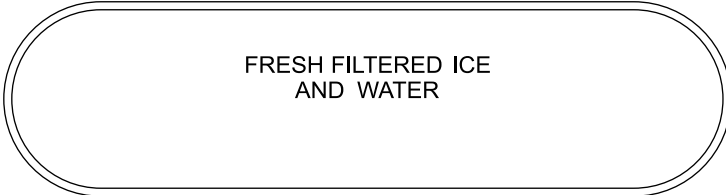
## Condenser Fan Motor Removal (\_7 Series Shown)

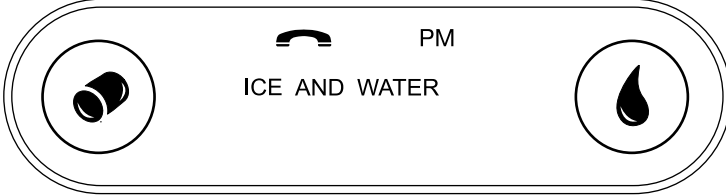
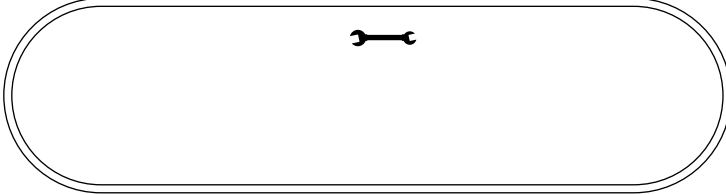

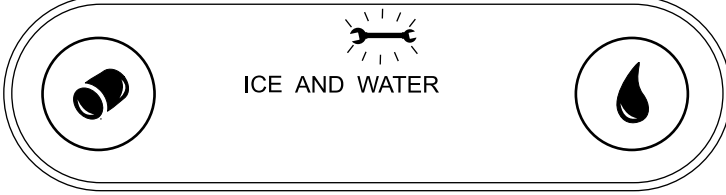
## User Interface Display Identification

Operation Display	Condition	Procedure
	Normal operation	—
	Cleaning Mode	Press and release maintenance/clean switch to clean the user interface without dispensing ice or water (see <a href="#">Maintenance/Cleaning Mode on page 12</a> ).
	Drip tray full	Empty drip tray.
	Six-month periodic maintenance required	Follow Maintenance Mode procedure (below) and also see <a href="#">Cleaning and Sanitizing Procedure on page 14</a> .
	Maintenance Mode	Enter Maintenance Mode by pressing maintenance/clean switch until  displays. Complete the cleaning and sanitizing procedure shown on <a href="#">page 14</a> and change the filter, if so equipped. Exit Maintenance Mode by pressing and holding maintenance/clean switch until  no longer displays.
	Service - 8000 hr bushing check	Call Follett Technical Service Group at (877) 612-5086 or +1 (610) 252-7301. The flashing wrench indicates that the 8000 hr bushing check is required.

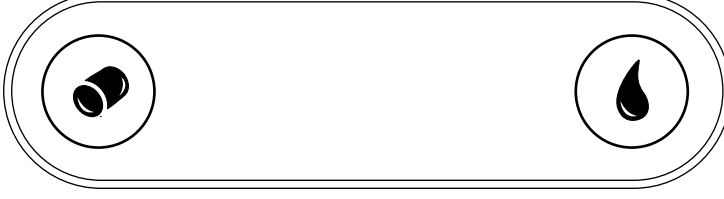
Service Display	Condition	Procedure
	Internal leak in dispenser	Locate leak and repair - Press reset on control board. Contact Follett if unit is leaking.
	Sleep mode	Press either dispense button to return to normal operation.

# Electrical Wiring Diagram

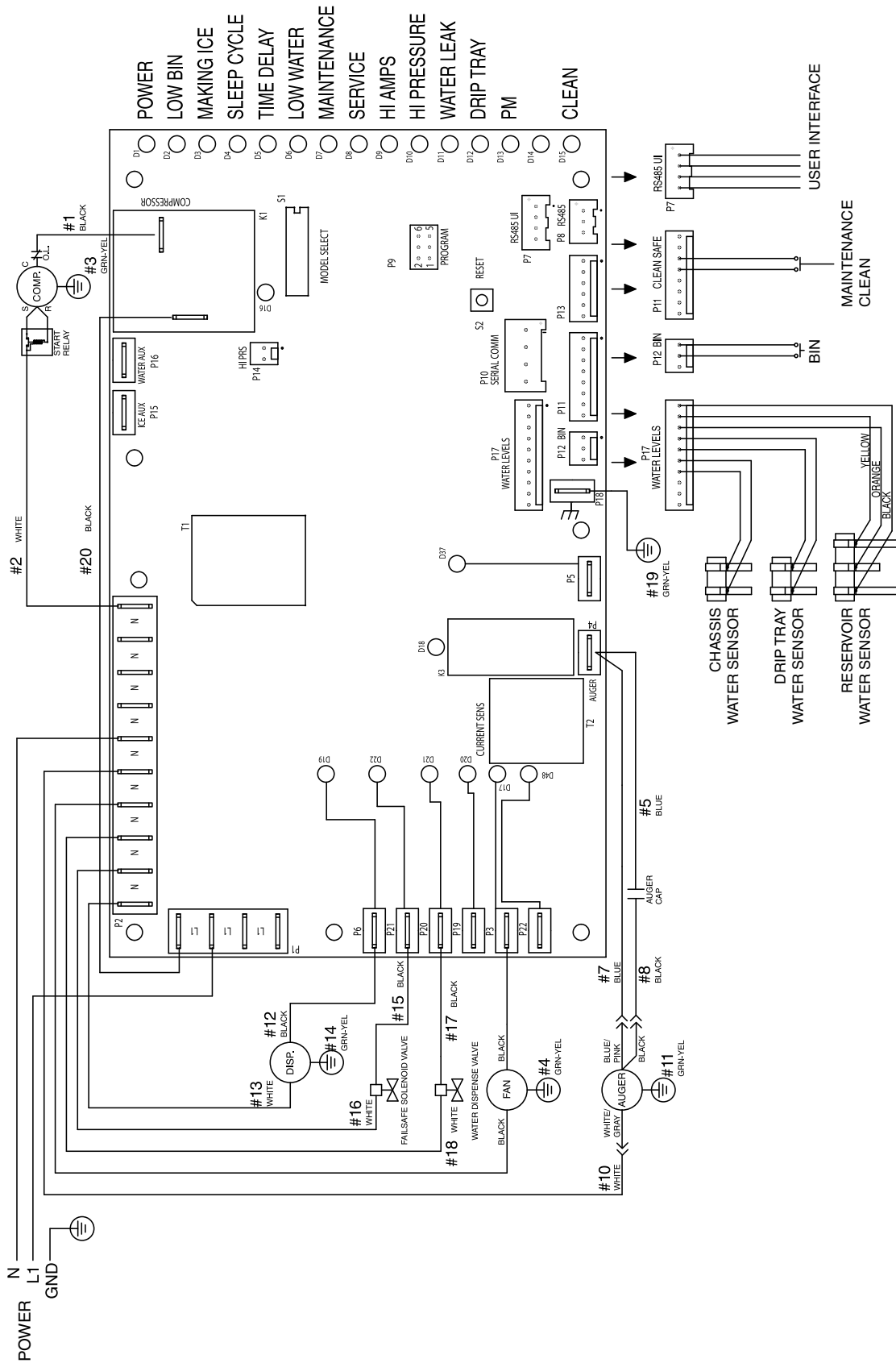

# Parts

## \_7 Series Exterior

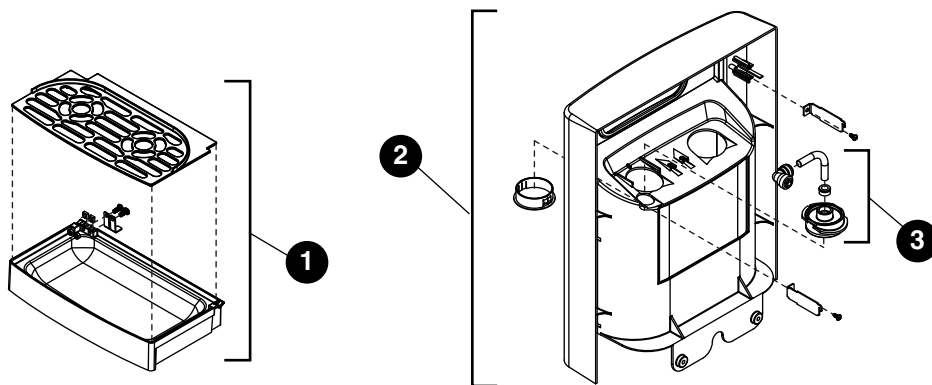
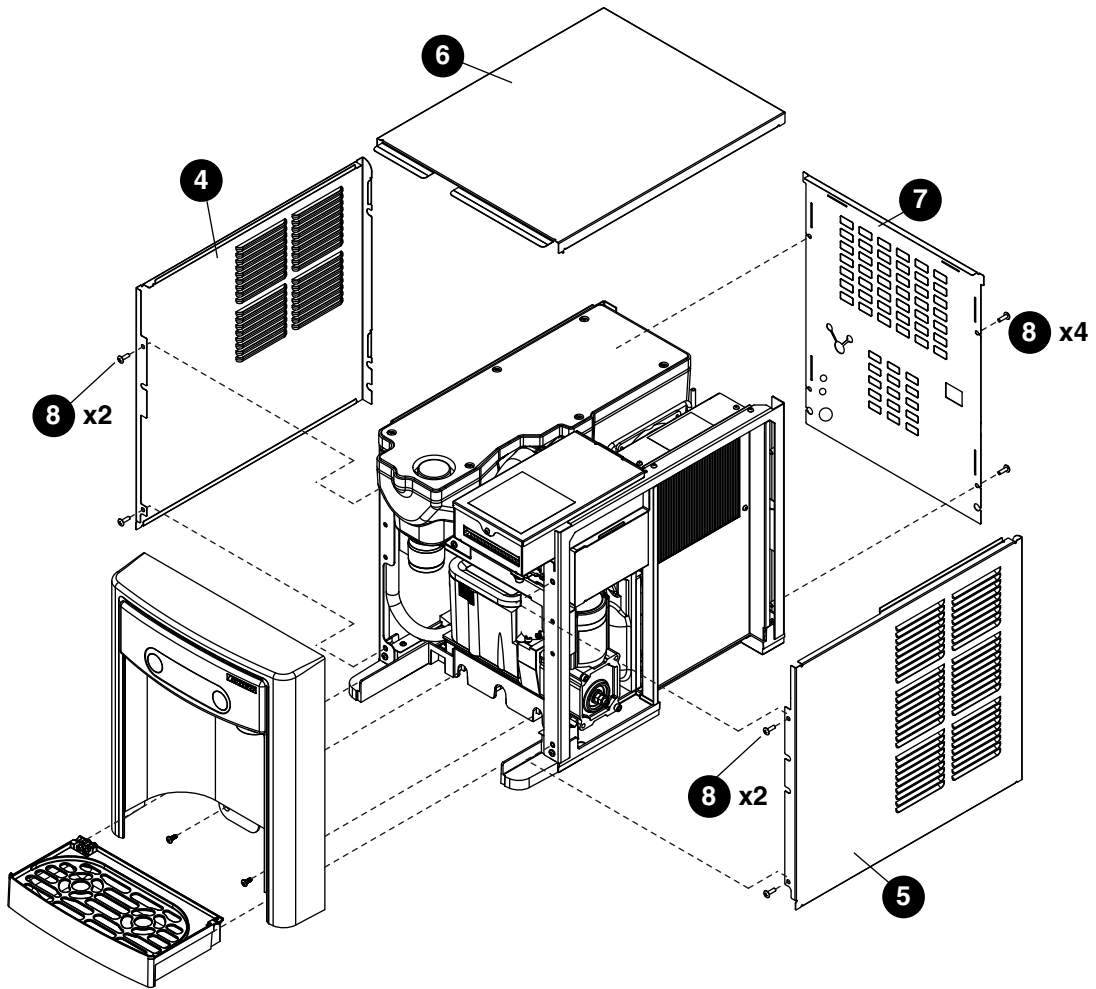

**Exterior**

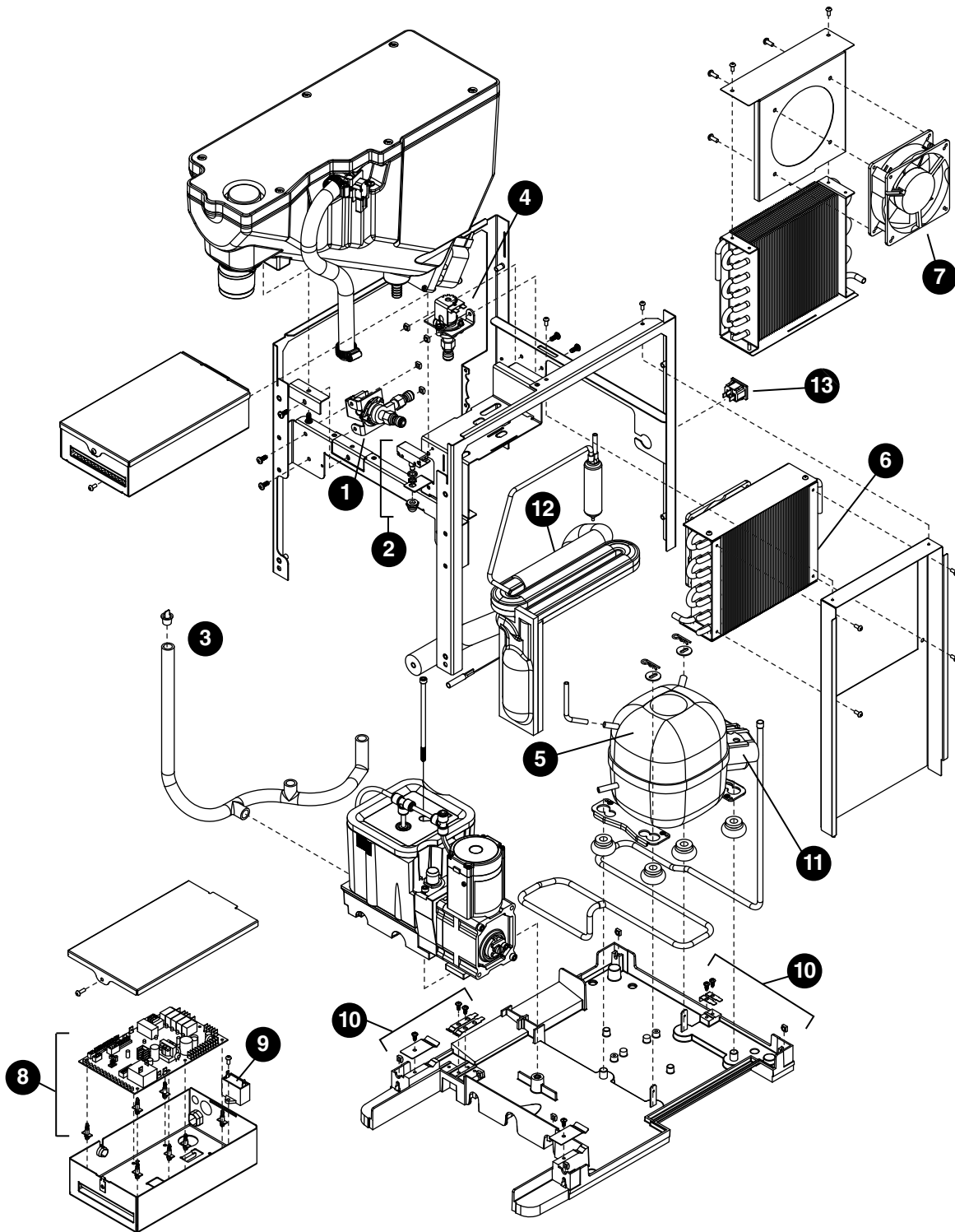

<b>Reference #</b>	<b>Description</b>	<b>Part #</b>
1	Drip Tray Assy	00957613
2	Panel, Front Assy - Includes Water Nozzle and Plug	00957621
3	Chute, Water (water option)	00957688
4	Panel, Left	00932806
5	Panel, Right	00932798
6	Panel, Top	00957654
7	Panel, Rear	00974873
8	Screw, M5 x 12 Phillips	00931931
Not Shown	_7 Series Packaging for Returns, Dispenser	00957993
Not Shown	Fitting, Elbow - 1/4" FPT x 1/4" Tube	00974261
Not Shown	Fitting, Elbow - 1/4" FPT x 3/8" Tube	00990796
Not Shown	Drip Tray Drain Kit	00956375
Not Shown	Drip Tray Drain Kit with 4" legs	00981977
Not Shown	Covers, Agion, User Interface	00969030

\_7 Series Interior



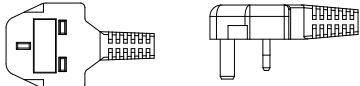
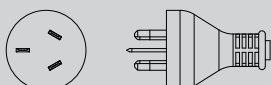
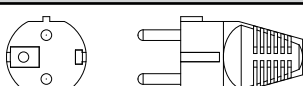
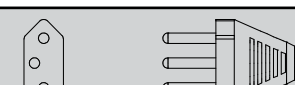

**Interior**

Reference #	Description	Part #
1	Valve, Dispense Solenoid (water option)	00968917
2	Switch, Cleaning	00957712
3	Drain/Feed Tube with Cap	00957720
4	Valve, Failsafe Solenoid	00968925
5	Compressor with Mounting Hardware (230 V/50 Hz)	00968933
5	Compressor with Mounting Hardware (220 V/60 Hz)	01062314
6	Condenser	00958017
7	Condenser Fan and Cord	00968941
8	Control Board with Stand-offs	00969048
9	Capacitor, Gearmotor	00968958
10	Sensor, Retainer Hardware Kit	00958066
11	Relay and Overload (230 V/50 Hz)	00968966
11	Relay and Overload (220 V/60 Hz)	01065143
12	Refrigeration, Piping Assy	00958132
13	Power Input	00968974
Not Shown	Cord, Power IEC60320-C13 to BS 1363	 00976753
Not Shown	Cord, Power IEC60320-C13 to AS 3112	 00976761
Not Shown	Cord, Power IEC60320-C13 to CEE 7/7	 00976779
Not Shown	Cord, Power IEC60320-C13 to NBR 14136	 01063320
Not Shown	Cord, Power IEC60320-C13 to KSC 8305	 01063338
Not Shown	Cord, Power IEC60320-C13 to NEMA 5-15	 01063346

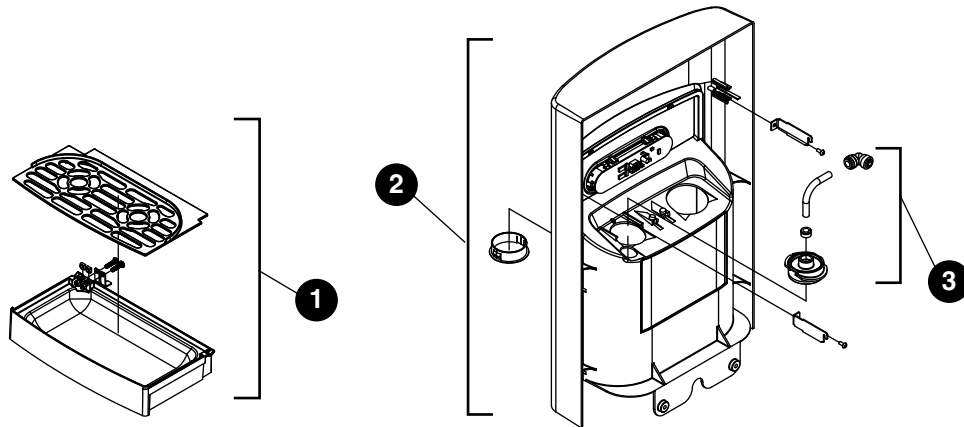
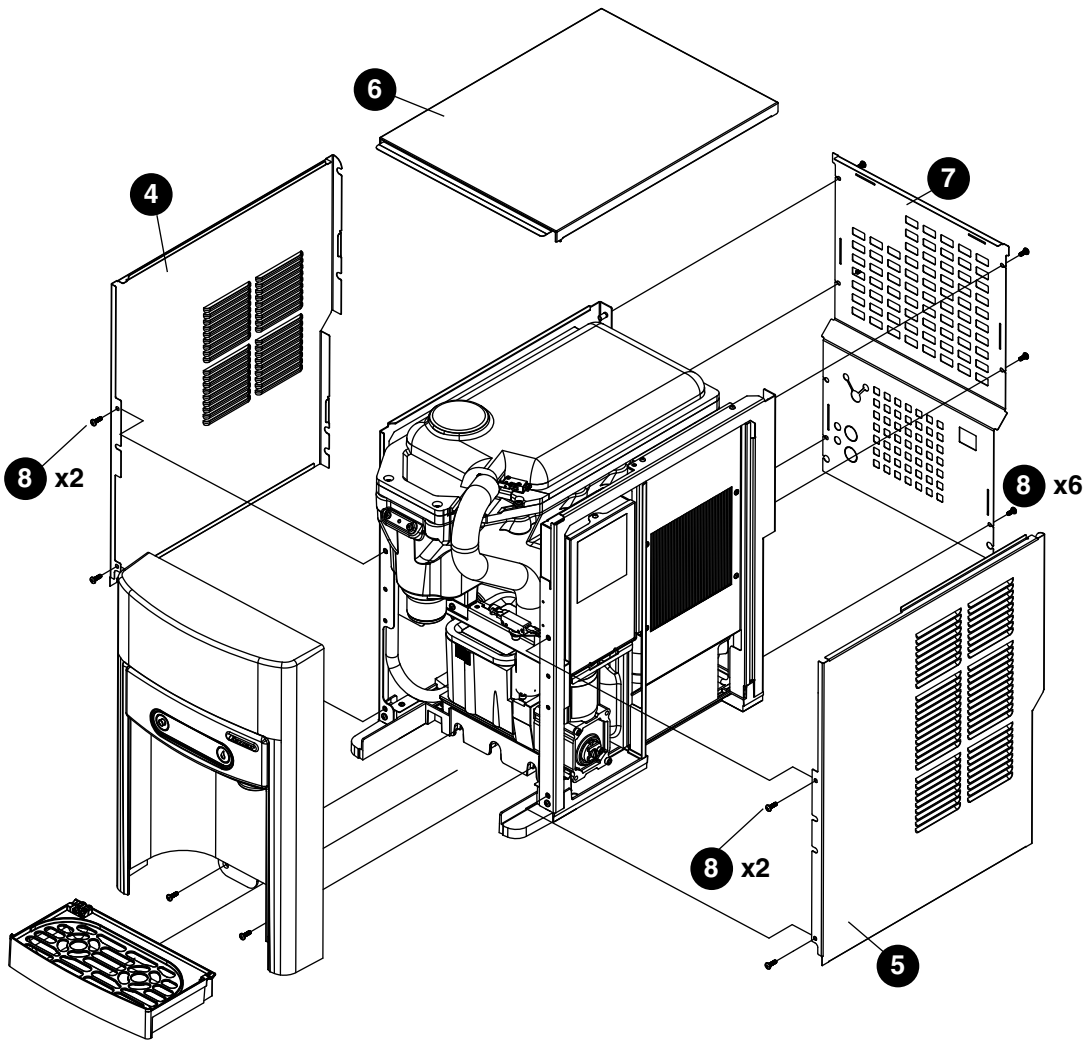

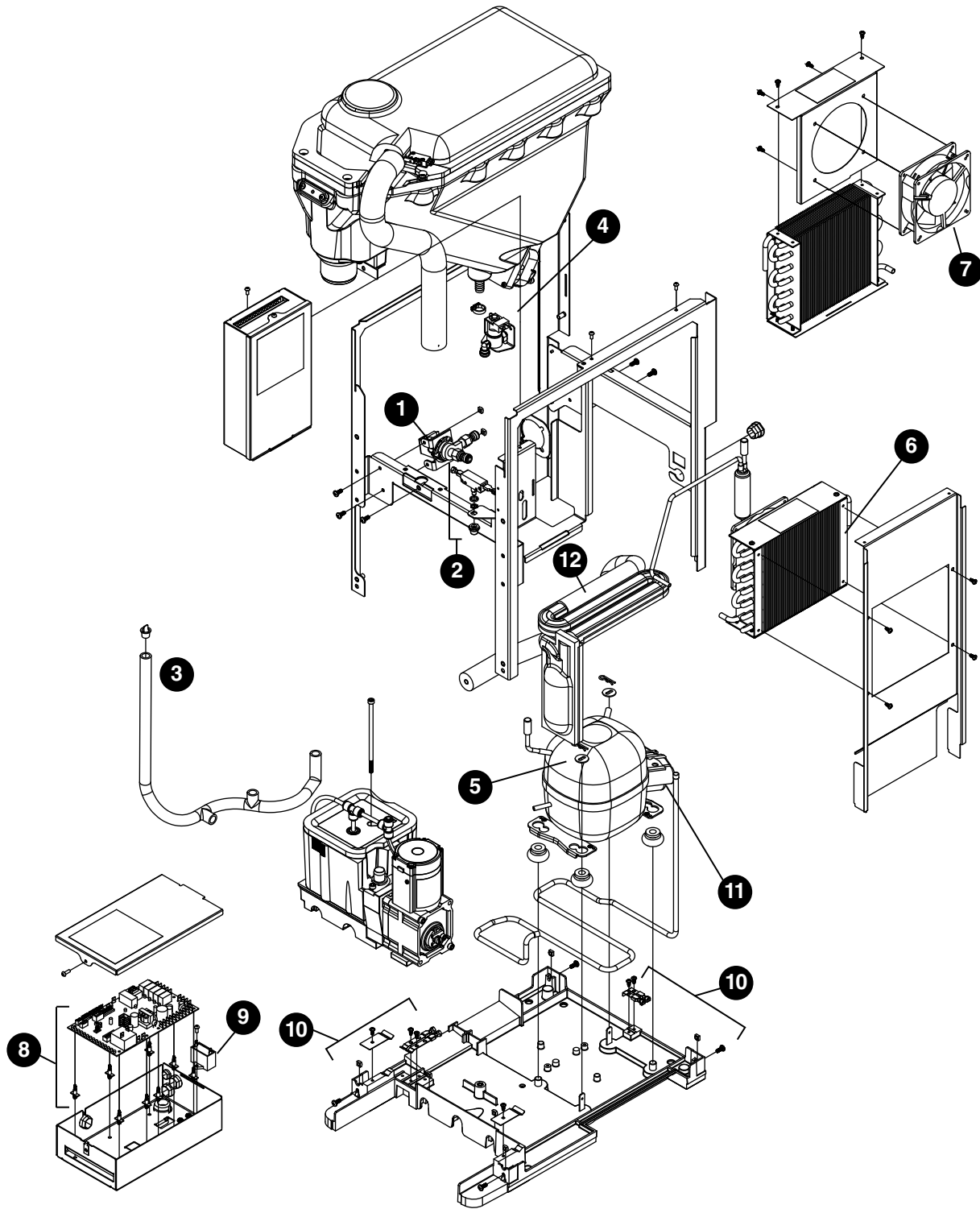

**Exterior**

<b>Reference #</b>	<b>Description</b>	<b>Part #</b>
1	Drip Tray Assy	00957613
2	Panel, Front Assy - Includes Water Nozzle and Plug	01036425
3	Chute, Water (water option)	00957688
4	Panel, Left	01026343
5	Panel, Right	01026335
6	Panel, Top	01054733
7	Panel, Rear	01047729
8	Screw, M5 x 12 Phillips	00931931
Not Shown	_15 Series Packaging for Returns, Dispenser	01054634
Not Shown	Fitting, Elbow - 1/4" FPT x 1/4" Tube	00974261
Not Shown	Fitting, Elbow - 1/4" FPT x 3/8" Tube	00990796
Not Shown	Drip Tray Drain Kit	00956375
Not Shown	Drip Tray Drain Kit with 4" legs	00981977

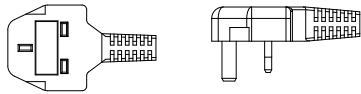
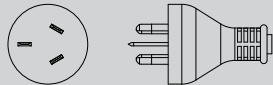
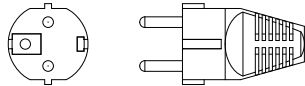

**Interior**

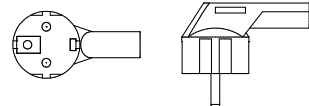
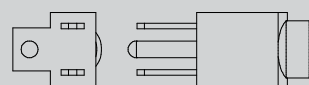
Reference #	Description	Part #
1	Valve, Dispense Solenoid (water option)	00968917
2	Switch, Cleaning	00957712
3	Drain/Feed Tube with Cap	00957720
4	Valve, Failsafe Solenoid	00968925
5	Compressor with Mounting Hardware (230 V/50 Hz)	00968933
5	Compressor with Mounting Hardware (220 V/60 Hz)	01062314
6	Condenser	00958017
7	Condenser Fan and Cord	00968941
8	Control Board with Stand-offs	01051986
9	Capacitor, Gearmotor	00968958
10	Sensor, Retainer Hardware Kit	00958066
11	Relay and Overload (230 V/50 Hz)	00968966
11	Relay and Overload (220 V/60 Hz)	01065143
12	Refrigeration, Piping Assy	00958132
13	Power Input	00968974
Not Shown	Cord, Power IEC60320-C13 to BS 1363	 00976753
Not Shown	Cord, Power IEC60320-C13 to AS 3112	 00976761
Not Shown	Cord, Power IEC60320-C13 to CEE 7/7	 00976779
Not Shown	Cord, Power IEC60320-C13 to NBR 14136	 01063320
Not Shown	Cord, Power IEC60320-C13 to KSC 8305	 01063338
Not Shown	Cord, Power IEC60320-C13 to NEMA 5-15	 01063346

# \_7 Series Bin Assembly

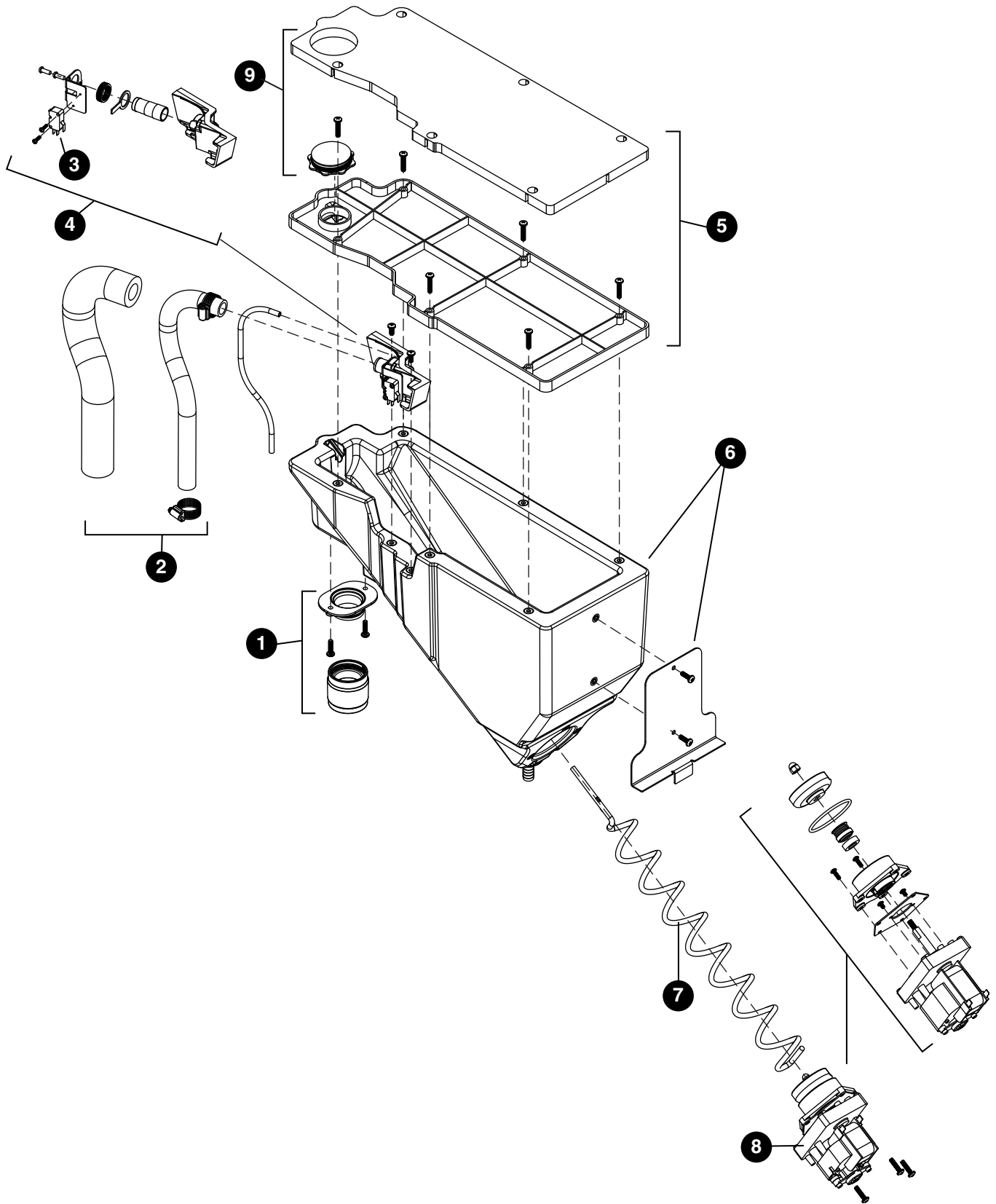

**\_7 Series Bin Assembly**

<b>Reference #</b>	<b>Description</b>	<b>Part #</b>
1	Ice Chute Assembly	00957670
2	Ice Transport Tubing with Insulation	00957746
3	Switch, Shuttle	00957753
4	Shuttle, Complete Assy	00957761
5	Lid, Bin Assy	00957779
6	Bin, Assy	00957787
7	Auger, Dispense	00931113
8	Assembly, Motor Dispense	00968982
9	Cap and Insulation, Bin	00957936
Not Shown	For serial numbers D17619 and below:	
	Bin Cap	00931519
	Ice Chute	00927210
	Chute Adapter	00926550

15 Series Bin Assembly

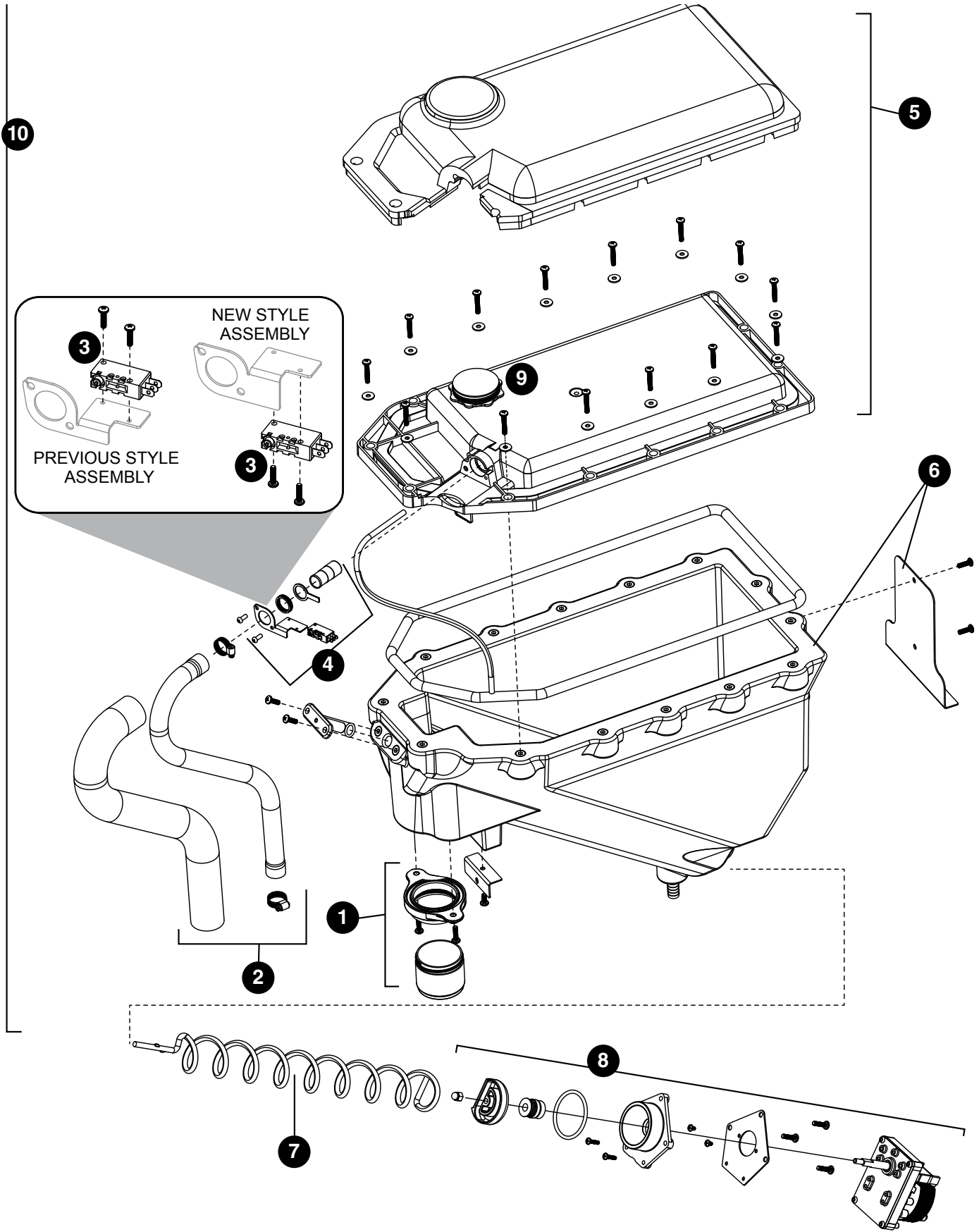



## **\_15 Series Bin Assembly**

<b>Reference #</b>	<b>Description</b>	<b>Part #</b>
1	Ice Chute Assembly	01051846
2	Ice Transport Tubing with Insulation	01051960
3	Switch, Shuttle (does not include bracket)	00957753
4	Shuttle, Complete Assy	01053248
5	Lid, Bin Assy	01053255
6	Bin, Assy	01053263
7	Auger, Dispense	01026251
8	Assembly, Motor Dispense	00968982
9	Cap and Insulation, Bin	01053305
10	Bin assembly, 15 Series (does not include ice transport tube and insulation)	01164888

# Evaporator Assembly

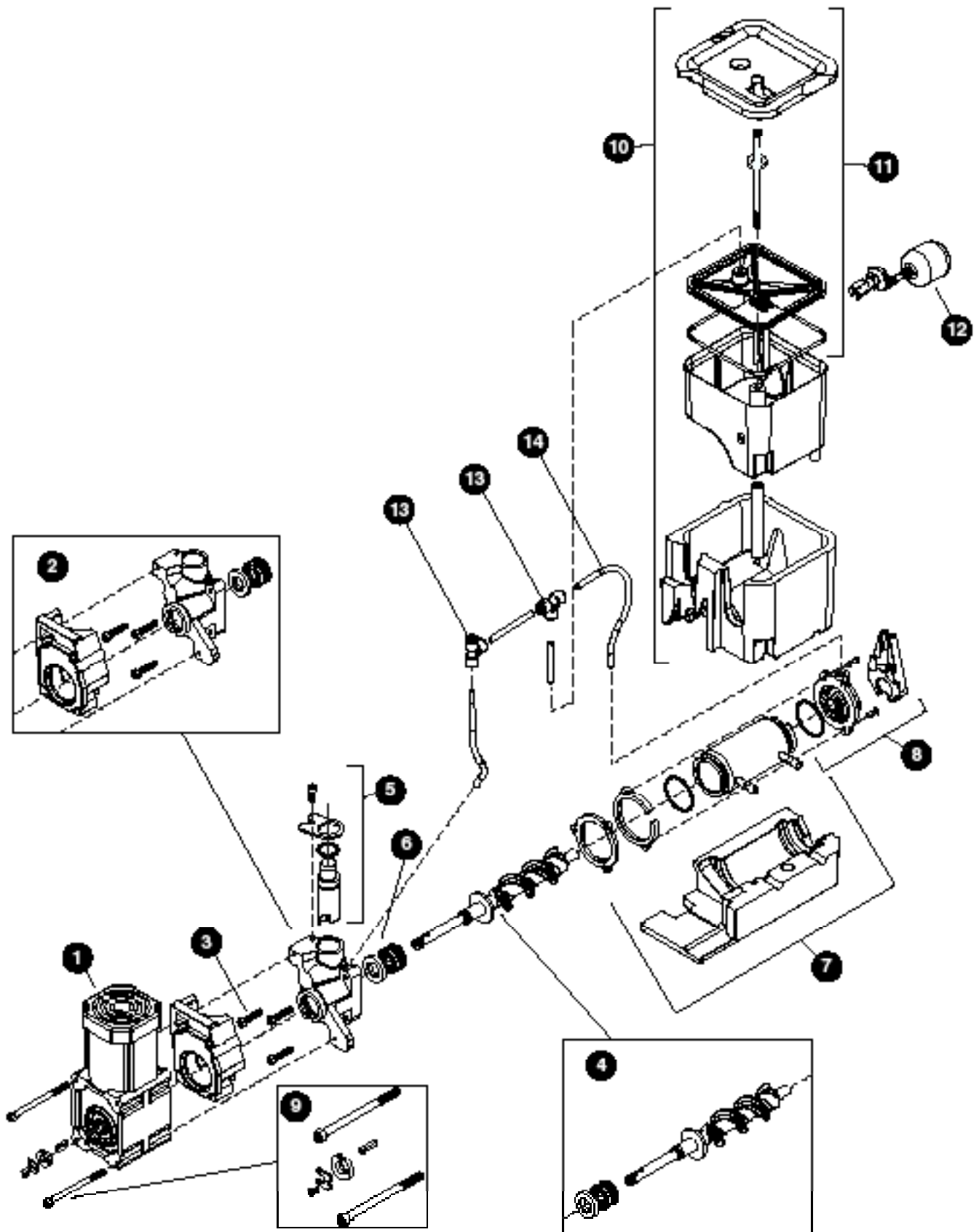

## Evaporator Assembly

Reference #	Description	Part #
1	Gearmotor Assy	00968990
2	Main Housing with Front Seal and Screws	00957829
3	Screws, Main Housing	00957837
4	Auger with front seal	00957845
5	Ice Compression Nozzle Assy	00957852
6	Front Seal and O-Ring	00957860
7	Evaporator Assembly with Insulation	00957878
8	Housing, Bushing with Insulation	00957886
9	Hardware kit, Gearmotor (For serial numbers E01087 and above)	01048628
9	Hardware kit, Gearmotor (For serial numbers below E01087)	00957894
10	Reservoir and Float Complete Assy	00957902
11	Lid, Reservoir with Insulation and O-Ring	00957910
12	Float Valve	00957928
13	"T" Fitting - 1/4"	502923
14	Tubing - 1/4" (sold in 12" increments)	502079

## Base Stand

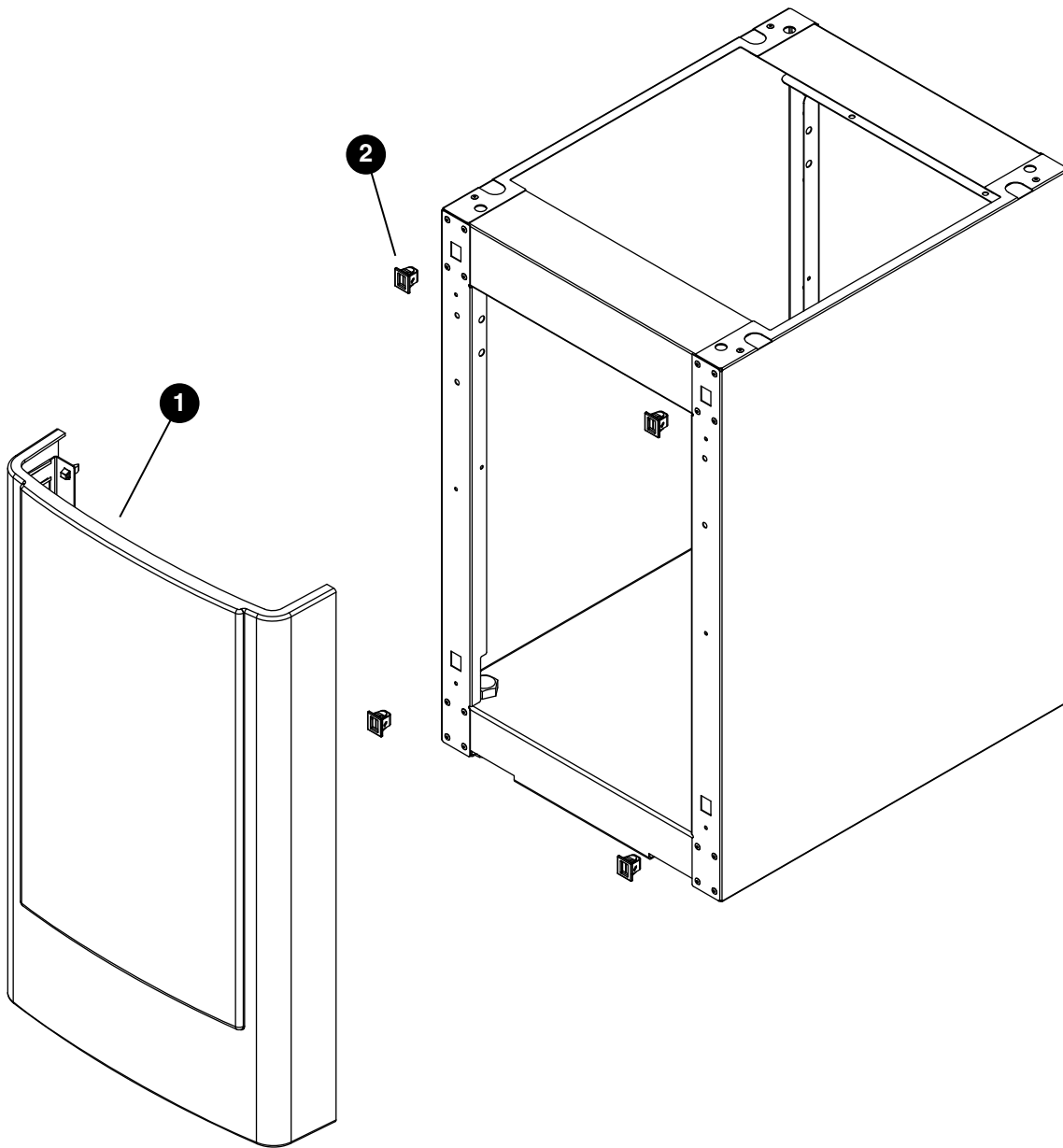

**Base Stand**

Reference #	Description	Part #
1	Front Panel, Base	00958108
2	Latches with Bayonets, Base	00958116
Not Shown	Tray, Base	00958124
Not Shown	Packaging for Returns, Base	00957985

**Miscellaneous**

Reference #	Description	Part #
Not Shown	Water filter cartridge, 5 micron	00968107
Not Shown	IMS III sanitizer concentrate, 16 oz	00979674
Not Shown	SafeCLEAN Plus liquid, 6 pack	01149954
Not Shown	SafeCLEAN Plus liquid, case of 24	01149962
Not Shown	6" Legs for base stand, set of 4	00956318
Not Shown	4" Legs for countertop dispenser, set of 4	00956300





## Warranty Registration and Equipment Evaluation

Thank you for purchasing Follett® equipment. Our goal is to deliver high value products and services that earn your complete satisfaction by delivering high-value products and services backed by outstanding customer and technical support.

Please review the installation instructions thoroughly. It is important that the installation be performed to factory specifications so your equipment operates at its maximum efficiency.

Follett LLC will not be liable for any consequential damages, expenses, connecting or disconnecting charges, or any losses resulting from a defect of the machine. For full warranty details, visit our website [www.follettice.com/productwarranties](http://www.follettice.com/productwarranties).

Registering your equipments helps Follett track your equipment's service history should you need to contact us for technical support, and your feedback helps us improve our products and services. Please visit [www.follettice.com/support](http://www.follettice.com/support) to complete the Warranty Registration form.

Should you have any questions, please contact Follett's technical support group at (877) 612-5086 or (610) 252-7301 and we will be happy to assist you.

SafeCLEAN Plus is a trademark of Follett LLC.

Chewblet and Follett are registered trademarks of Follett LLC, registered in US.



801 Church Lane • Easton, PA 18040, USA  
Toll free (877) 612-5086 • +1 (610) 252-7301  
[www.follettice.com](http://www.follettice.com)

Follett Europe Polska Sp. z o.o.  
Mokry Dwór 26 c • 83-021 Wiślina, Poland  
+48 (58) 785-6140 • Fax +48 (58) 785-6159  
[www.folletteurope.com](http://www.folletteurope.com)



00976738R09  
© Follett LLC 6/18